

Service Manual

Models: JKFD5QSR/Na-E、JKFD5CR/Na-E

JKFD7QSR/Na-M、JKFD7CR/Na-M

JKFD15QSR/Na-M、JKFD15CR/Na-M

JKFD20QSR/Na-M、JKFD20CR/Na-M

JKFD25QS2/Na-M、JKFD25C2/Na-M、JKFD25SX2/Na-M

JKFD40QS2/Na-M、JKFD40C2/Na-M、JKFD40SX2/Na-M

(Refrigerant R410A)

GREE ELECTRIC APPLIANCES,INC.OF ZHUHAI

Table of Contents

I Product	1
1. Naming Convention of Products	2
2. Features of Product	3
3. System Principle	5
3.1 Flowchart of the System	5
3.2 Description of the System.....	5
4. Performance Parameters.....	6
5. PERFORMANCE CORRECTION	13
5.1 Correction of Cooling Capacity	13
5.2 Coefficient of Correction Table for Various Conditions of Installation	14
6. Installation of the unit	16
6.1 Installation Diagram of the Complete Unit	16
6.2 Outline Dimension of the Unit	16
6.3 Installation Dimension and Space	23
6.4 Requirements of Installation.....	28
7. Electric installation	33
7.1 Electrical Installation.....	33
7.2 Matching Form of Power Cord and Air Switch.....	37
II Control	39
1 Control of the Unit	39
1.1 General Control.....	39
1.2 Introduction to Key Control Logic of the Unit	41
2. Controller	42
2.1 Homepage.....	42
2.2 User Setting Interface	44
2.4 Running Status Interface	48
2.5 Event Log	51
2.6 Parameter Setting	52
2.7 System Information.....	55
2.8 Touch Screen Caring, Humidifier Maintenance and Installation Notice.....	59
3. The Instruction of DIP Switch.....	61
3.1 Address Code	61
3.2 Capacity Code	62
4. Remote Monitoring	63
4.1 Installation	63
4.2 Operation	65
4.3 Display interface.....	75
4.4 Unit and equipment management	77
4.5 Parameter control	81
4.6 Running parameter view	84
4.7 User and role management.....	85
4.8 Others	87

III Maintenance	88
1. Malfunction List.....	88
2. Troubleshooting	93
2.1 High Pressure Protection of Compressor.....	93
2.2 Low Pressure Protection of Compressor	94
2.3 Discharge Temp Protection for Compressor.....	95
2.4 Overload Protection of Compressor.....	95
2.5 Overload Protection of Indoor Fan	96
2.6 Temperature Protection of Electric Heater	96
2.7 Low Current Malfunction, Drainage Malfunction and High Water Level Malfunction of Humidifier	97
2.8 Low Air Pressure Malfunction of Indoor Fan.....	98
2.9 Alarm for Blocking Filter	99
3. Case Study.....	100
4. Power Distribution of the Unit.....	103
4.1 Power Distribution Diagram.....	103
4.2 Circuit Diagram (The circuit diagram is for reference only and the circuit diagram on the unit is the standard.)	105
4.3 Introduction for Main Electric Parts	114
5. Disassembly and Assembly of the Unit.....	116
5.1 Introduction to Key Parts	116
5.2 Assembly and Disassembly of Parts.....	118
6. Exploded View and Parts List	120

I Product



Indoor Unit



Outdoor Unit

1. Naming Convention of Products

JK	F	D	40	QS	□	2	□	□	/	□	-	M	(I)
1	2	3	4	5	6	7	8	9		10		11	12

NO.	Description	Option
1	Product Classification	JK-Closed Control Air Conditioner
2	Cooling Method and Structure	Omitted—Water-cooled Packaged Unit F—Air-cooled Split Unit Y—Ethylene Glycol-cooled Split Unit C—Chilled Water Unit
3	Unit Type	Omitted—Cooling Only Unit (without electric heater) D—Cooling Only Unit +Electric Heater Z—Cooling Only Unit+ Refrigerant plus Heater
4	Cooling Capacity	Nominal Cooling Capacity--number (kW)
5	Direction of Air Intake and Discharge	C—Direct Air Supply (with air cap) SX—Top Air Intake and Bottom Air Discharge (air supplied from floor) QS—Front Air Intake and Top Air Discharge (air duct is connected)
6	Structure Type	Omitted—Compressor Indoors W—Compressor Outdoors
7	Number of System Combination	Omitted—One System 2—Two Systems
8	Humidifier	Omitted—Standard Electrode Humidifier R—Infrareded Humidifier N—Without Humidifier
9	Compressor Type	Omitted—Fixed frequency P—AC Inverter Pd—DC Inverter
10	Refrigerant	Omitted—R22 N—R407c Na—R410A
11	Power SupplyType	M—380V 3N~ 50Hz E—220V ~ 50Hz
12	Codes of Indoor and Outdoor Units	Omitted—Complete Unit and Integral Type I—Indoor Units O—Outdoor Units

2. Features of Product

Gree JKF Series Air-cooled Closed Control Unit is specially designed for the room where communication equipment, computer, and precise instruments are placed. Applying components with high performance, wide and touchable screen, advanced system design as well as powerful control logic, the unit can efficiently control ambient humidity and keep stable and long-term operation. The unit has been thoroughly tested with high standard and has been under strict production control. All units have reserved remote monitoring function. Cooling capacity of a single unit is between 5kW~40kW and can be expanded by combination of modules.

◆ Powerful control function

Touchable screen control: with 7" touch screen to achieve easy, swift and convenient control and operation.

All-sided monitoring: inspect the operation of the unit in all sides, including ambient temp and humidity, temperature of evaporator, status of each component of the unit. (such as indoor or outdoor fan, compressor, electric heater, etc), voltage, current, etc)

Multi functions display: use value, phrases, and curves to display data regarding operation of the unit or environmental phenomenon.

Human-friendly control: each parameter or warning can be set according to the demand of user. If malfunction occurs, the unit will give warning and, at the same time, it will keep running or stop, which is selected according to the type of the malfunction.

Operation without watch: the unit can automatically operate according to set time of starting or turning off. If the unit stops due to power failure, the unit will automatically operate at previous status after power recovery. The operation of the unit can be remotely monitored and at any time, the unit can be set from long distance.

◆ High performance and high reliability

High performance: using brandname scroll compressor, female screw thread copper pipe, Hydrophilic film aluminum fin, condensate fan with stepless regulation, the unit can reach high efficiency and be energy-saving.

High reliability: All components are brandname products and be inspected by IQC of Gree. The unit is strictly tested and can stably operate for long-term.

Operation under ultra low temperature: the unit can reliably operate even though outdoor temperature is -35°C. The room temperature and humidity can be stable under all kinds of rough conditions.

High sensible heat: it is designed for work condition with high sensible heat and can reduce repeated humidifying as well as avoid condensate.

Huge air volume: use high efficient centrifugal fan which produces huge circulated air volume to rapidly make temperature and humidity in the room even and clear local heat generation.

Rapid dry: the evaporator has two-stage. In dry mode, by reducing heat exchange area of evaporator and evaporating temperature, the unit can rapidly dry and precisely control ambient temperature and humidity.

◆ Modular Design

High Precision: High precision: each module can be individually controlled. The cooling capacity can also be individually controlled to flexibly adapt to environment and decrease fluctuation of temperature and humidity.

Alternate operation: According to accumulated operation time, the unit which has less operation time will start operation firstly while the unit which has more operation time will stop firstly. Each module can alternately operate and be evenly controlled. If any module has malfunction, others will automatically operate.

Convenient expanding of capacity: max. 253 master modules can be connected so the problem of increasing heat load of the room can be flexibly handled and cost of further capacity expanding by customer can be reduced.

Flexible installation: Single module can be casually installed according to layout of the room, which makes the humidity and temperature of the room more even.

Convenient transportation: the single module is separately packaged so transportation and installation are more convenient.

◆ Structure Features

Separate electric control: electric control cabinet is totally separate with cold air circulation system so there is no incipient fault caused by condensate and short circuit.

Convenient disassembly: main front panel Assy is fixed by clasp so the disassembly is very convenient and the appearance is also nice.

High efficient filtering: There is G4 grade wide air filter in air return inlet of indoor unit to guarantee cleanness and reduce loss of air pressure.

Snow-proof design: for outdoor unit, the air returned from the bottom and supplied from the top to prevent the vent from being blocked by snow.

◆ Multi products

Wide cooling range: GREE JKF series air-cooled closed control units include 5kW, 7kW, 15kW, 20kW, 25kW and 40kW units. And also, with combination of modules, customers can easily select proper units according to their demand.

Various air outlet ways: Each kind of unit has three ways of air outlet, including free air outlet (with cap), front air inlet and top air outlet (connecting to duct type), top air inlet and bottom air outlet (air supplied from floor). Customers can freely select the units according to specific conditions.

3. System Principle

3.1 Flowchart of the System

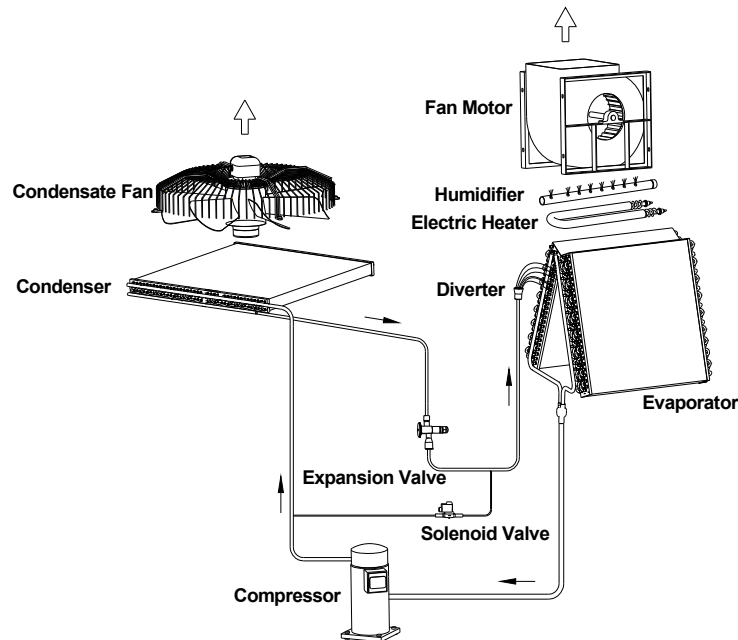

3.2 Description of the System

Structural features and system layout of JKF Series Air-cooled Closed Control Air Conditioner are illustrated as above.

By compressor used for cooling and dehumidifying, electric heater for heating and temperature adjustment, electrode humidifier for humidifying and logical program to control the even running of every functional part, the unit adjusts the ambient temperature and humidity so that it can meet the requirement of maintaining the precise temperature and humidity.

When the unit is running, the flowchart of refrigerant system is as below :

Scroll compressor → Air cooled condenser (brass forge louver type aluminum plate-fin)
 →Liquid filter→ Expansion valve→Tritorium → Evaporator (Brass forge louver type aluminum plate-fin) → Scroll compressor

Flow direction of air supply system:

Return air → Plate type filter → Evaporator→Electric Heater→Nozzle of humidifier → Centrifugal fan→ Air-conditioned room.

4. Performance Parameters

Form 1

Class	Item	Model		JKFD5CR/Na-E	JKFD5QSR/Na-E
		Unit			
	Code of Product			EJ13000480	EJ13000440
Characteristics of Units	Total Cooling Capacity / Sensible Cooling Capacity(22°C/50%)	kW		5.3/4.8	
	Total Cooling Capacity / Sensible Cooling Capacity(24°C/17°C)	kW		5.5/5.1	
	Total Cooling Capacity / Sensible Cooling Capacity(24°C/45%)	kW		5.4/4.9	
	Total Cooling Capacity / Sensible Cooling Capacity(26°C/50%)	kW		5.7/5.2	
	Heating Capacity	kW		2.7	
	Rated Humidifying Capacity	kg/h		2	
	Air Flow Volume	m ³ /h		1900	1900
	External Static Pressure	Pa		0	15
	Acoustic Noise of Indoor Units	dB(A)		58	56
	Range of Temp. Controlling and Precision			17~28°C±1°C	
	Range of Humidity and Precision			40~60%±5%	
	Power Supply			220V~ 50Hz	
Cooling System	Compress	Type	Hermetic Scroll Type		
	Evaporat	Type	Inner Screw Thread Pipe with Hydrophilic Film Aluminum Fin		
	Condens	Type	Inner Screw Thread Pipe with Hydrophilic Film Aluminum Fin		
	Refrigerant		R410A		
	Throttling Method		Electronic Expansion Valve		
Air Supply System	Indoor Unit	Fan	Type	Low Noise and Centrifugal External-rotor	
			Type of	Direct Drive	
		Air Filter	Type	Plate Filter (G4)	
Heating System	Heater	Type	Electric Heating		
Humidifying System	Humidifier	Type	Infrared Type		
		Control Mode	Automatic Control by Mainboard		
Indoor Unit	Indoor Unit Model		JKFD5CR/Na-E(I)	JKFD5QSR/Na-E(I)	
	Dimension	W	mm	800	800
		D	mm	700	700
		H	mm	2250	1950
	Net Weight		kg	257	237
Outdoor Unit	Outdoor Unit Model		JKFD5P/Na-E(O)		
	Qty	Set	1		
	Condensing Fan	Type	Low Noise Axial Type		
		Type of Drive	Direct Drive		
	Noise		dB(A)	60	
	Dimension	W	mm	900	
		D	mm	412	
H		mm	1350		

GREE Air-cooled Closed Control Unit Service Manual

	Net Weight	kg	71
Connection pipe	Liquid Refrigerant	mm×pcs	Φ9.52×1
	Gas Refrigerant Pipe	mm×pcs	Φ12×1
	Method of Connection		Flared-fitting Joint

Form 2

Class	Item	Model Unit	JKFD7CR/Na-M	JKFD7QSR/Na-M		
	Code of Product		EJ13000490	EJ13000450		
Characteristics of Units	Total Cooling Capacity / Sensible Cooling Capacity(22°C/50%)	kW	6.8/5.8			
	Total Cooling Capacity / Sensible Cooling Capacity(24°C/17°C)	kW	7.2/6.5			
	Total Cooling Capacity / Sensible Cooling Capacity(24°C/45%)	kW	7.0/6.3			
	Total Cooling Capacity / Sensible Cooling Capacity(26°C/50%)	kW	7.3/6.6			
	Heating Capacity	kW	2.7			
	Rated Humidifying Capacity	kg/h	4			
	Air Flow Volume	m ³ /h	1950	1950		
	External Static Pressure	Pa	0	15		
	Acoustic Noise of Indoor Units	dB(A)	63	55		
	Range of Temp. Controlling and Precision		17~28°C±1°C			
	Range of Humidity and Precision		40~60%±5%			
	Power Supply		220V~ 50Hz			
Cooling System	Compressor	Type	Hermetic Scroll Type			
	Evaporator	Type	Inner Screw Thread Pipe with Hydrophilic Film Aluminum Fin			
	Condenser	Type	Inner Screw Thread Pipe with Hydrophilic Film Aluminum Fin			
	Refrigerant		R410A			
	Throttling Method		Electronic Expansion Valve			
Air Supply System	Indoor Unit	Fan	Type	Low Noise and Centrifugal External-rotor		
			Type of	Direct Drive		
	Air Filter	Type	Plate Filter (G4)			
Heating System	Heater	Type	Electric Heating			
Humidifying System	Humidifier	Type	Infrared Type			
		Control Mode	Automatic Control by Mainboard			
Indoor Unit	Indoor Unit Model		JKFD7CR/Na-M(I)	JKFD7QSR/Na-M(I)		
	Dimension	W	mm	800	800	
		D	mm	700	700	
		H	mm	2250	1950	
	Net Weight		kg	257	237	
Outdoor Unit	Outdoor Unit Model		JKFD7P/Na-E(O)			
	Qty		Set	1		
	Condensing Fan	Type		Low Noise Axial Type		
		Type of Drive		Direct Drive		
	Noise		dB(A)	60		
	Dimension	W	mm	900		
D		mm	412			

GREE Air-cooled Closed Control Unit Service Manual

		H	mm	1350
	Net Weight		kg	71
Connection pipe	Liquid Refrigerant Pipe		mm×pcs	Φ9.52×1
	Gas Refrigerant Pipe		mm×pcs	Φ12×1
	Method of Connection			Flared-fitting Joint

Form 3

Class	Item	Model Unit	JKFD15CR/Na-M	JKFD15QSR/Na-M	
	Code of Product		EJ13000500	EJ13000460	
Characteristics of Units	Total Cooling Capacity / Sensible Cooling Capacity(22°C/50%)		14.8/13.5		
	Total Cooling Capacity / Sensible Cooling Capacity(24°C/17°C)		15.0/13.6		
	Total Cooling Capacity / Sensible Cooling Capacity(24°C/45%)		14.9/13.8		
	Total Cooling Capacity / Sensible Cooling Capacity(26°C/50%)		16.6/15.0		
	Heating Capacity		5.8	7	
	Rated Humidifying Capacity		4	4	
	Air Flow Volume		3700	4800	
	External Static Pressure		0	75	
	Acoustic Noise of Indoor Units		64	62	
	Range of Temp. Controlling and Precision		17~28°C±1°C		
	Range of Humidity and Precision		40~60%±5%		
	Power Supply		380V 3N~ 50Hz		
Cooling System	Compressor	Type	Hermetic Scroll Type		
	Evaporator	Type	Inner Screw Thread Pipe with Hydrophilic Film Aluminum Fin		
	Condenser	Type	Inner Screw Thread Pipe with Hydrophilic Film Aluminum Fin		
	Refrigerant		R410A		
	Throttling Method		Electronic Expansion Valve		
Air Supply System	Indoor Unit	Fan	Type	Low Noise and Centrifugal External-rotor	
			Type of	Direct Drive	
		Air Filter	Type	Plate Filter (G4)	
Heating System	Heater	Type		Electric Heating	
Humidifying System	Humidifier	Type		Infrared Type	
		Control Mode		Automatic Control by Mainboard	
Indoor Unit	Indoor Unit Model		JKFD15CR/Na-M(I)	JKFD15QSR/Na-M(I)	
	Dimension	W	mm	980	980
		D	mm	950	950
		H	mm	2250	1950
Net Weight		kg	380	348	
Outdoor Unit	Outdoor Unit Model		JKFD15P/Na (0)		
	Qty		Set	1	
	Condensing Fan	Type		Low Noise Axial Type	
		Type of Drive		Direct Drive	
	Noise		dB(A)	64	
	Dimension	W	mm	1400	
D		mm	715		

GREE Air-cooled Closed Control Unit Service Manual

		H	mm	1130
	Net Weight		kg	136
Connection pipe	Liquid Refrigerant Pipe		mm×pcs	Φ12×1
	Gas Refrigerant Pipe		mm×pcs	Φ16×1
	Method of Connection			Flared-fitting Joint

Form 4

Class	Item	Model Unit	JKFD20CR/Na-M	JKFD20QSR/Na-M	
	Code of Product		EJ13000510	EJ13000470	
Characteristics of Units	Total Cooling Capacity / Sensible Cooling Capacity(22°C/50%)		19.0/18.0		
	Total Cooling Capacity / Sensible Cooling Capacity(24°C/17°C)		20.0/18.4		
	Total Cooling Capacity / Sensible Cooling Capacity(24°C/45%)		19.8/18.8		
	Total Cooling Capacity / Sensible Cooling Capacity(26°C/50%)		21.3/19.9		
	Heating Capacity		10	10.5	
	Rated Humidifying Capacity		4	4	
	Air Flow Volume		4150	6000	
	External Static Pressure		0	75	
	Acoustic Noise of Indoor Units		63	61	
	Range of Temp. Controlling and Precision		17~28°C±1°C		
	Range of Humidity and Precision		40~60%±5%		
	Power Supply		380V 3N~ 50Hz		
Cooling System	Compressor	Type	Hermetic Scroll Type		
	Evaporator	Type	Inner Screw Thread Pipe with Hydrophilic Film Aluminum Fin		
	Condenser	Type	Inner Screw Thread Pipe with Hydrophilic Film Aluminum Fin		
	Refrigerant		R410A		
	Throttling Method		Electronic Expansion Valve		
Air Supply System	Indoor Unit	Fan	Type	Low Noise and Centrifugal External-rotor	
			Type of	Direct Drive	
		Air Filter	Type	Plate Filter (G4)	
Heating System	Heater	Type	Electric Heating		
Humidifying System	Humidifier	Type	Infrared Type		
		Control Mode	Automatic Control by Mainboard		
Indoor Unit	Indoor Unit Model		JKFD20CR/Na-M(I)	JKFD20QSR/Na-M(I)	
	Dimension	W	mm	980	
		D	mm	950	
		H	mm	2250	
Net Weight		kg	400	360	
Outdoor Unit	Outdoor Unit Model		JKFD20P/Na-M(O)		
	Qty		Set	1	
	Condensing Fan	Type		Low Noise Axial Type	
		Type of Drive		Direct Drive	
	Noise		dB(A)	64	
	Dimension	W	mm	1400	
D		mm	715		

GREE Air-cooled Closed Control Unit Service Manual

		H	mm	1130
	Net Weight		kg	136
Connection pipe	Liquid Refrigerant Pipe		mm×pcs	Φ16×1
	Gas Refrigerant Pipe		mm×pcs	Φ19×1
	Method of Connection			Flared-fitting Joint

Form 5

Class	Item	Model Unit	JKFD25C2/Na-M	JKFD25QS2/Na-M	JKFD25SX2/Na-M	
	Code of Product		EJ13000400	EJ13000320	EJ13000350	
Characteristics of Units	Total Cooling Capacity / Sensible Cooling Capacity(22°C/50%)		kW	26.5/23.8		
	Total Cooling Capacity / Sensible Cooling Capacity(24°C/17°C)		kW	27.0/24.3		
	Total Cooling Capacity / Sensible Cooling Capacity(24°C/45%)		kW	26.8/24.0		
	Total Cooling Capacity / Sensible Cooling Capacity(26°C/50%)		kW	27.6/24.5		
	Heating Capacity		kW	12		
	Rated Humidifying Capacity		kg/h	8		
	Air Flow Volume		m ³ /h	7800	7500	7500
	External Static Pressure		Pa	0	100	100
	Acoustic Noise of Indoor Units		dB(A)	66	68	68
	Range of Temp. Controlling and Precision			17~28°C±1°C		
	Range of Humidity and Precision			40~60%±5%		
	Power Supply			380V 3N~ 50Hz		
Cooling System	Compressor	Type	Hermetic Scroll Type			
	Evaporator	Type	Inner Screw Thread Pipe with Hydrophilic Film Aluminum Fin			
	Condenser	Type	Inner Screw Thread Pipe with Hydrophilic Film Aluminum Fin			
	Refrigerant			R410A		
Throttling Method			Electronic Expansion Valve			
Air Supply System	Indoor Unit	Fan	Type	Low Noise and Centrifugal External-rotor		
			Type of	Direct Drive		
	Air Filter	Type	Plate Filter (G4)			
Heating System	Heater	Type	Electric Heating			
Humidifying System	Humidifier	Type	Electrode Type			
		Control Mode	Automatic Control by Mainboard			
Indoor Unit	Indoor Unit Model		JKFD25C2/Na-M(I)	JKFD25QS2/Na-M(I)	JKFD25SX2/Na-M(I)	
	Dimension	W	mm	1900	1900	1900
		D	mm	810	810	810
		H	mm	2250	1950	1950
Net Weight		kg	585	570	535	
Outdoor Unit	Outdoor Unit Model		JKFD13/NaA-M(O)			
	Qty		Set	2		
	Condensing Fan	Type		Low Noise Axial Type		
		Type of Drive		Direct Drive		
	Noise		dB(A)	64		
Dimension	W	mm	1080			

GREE Air-cooled Closed Control Unit Service Manual

	D	mm	1180
	H	mm	960
Net Weight		kg	89
Connection pipe	Liquid Refrigerant Pipe	mm×pcs	Φ12×2
	Gas Refrigerant Pipe	mm×pcs	Φ16×2
	Method of Connection		Flared-fitting Joint

Form 6

Class	Item	Model Unit	JKFD40C2/Na-M	JKFD40QS2/Na-M	JKFD40SX2/Na-M	
	Code of Product		EJ13000430	EJ13000330	EJ13000360	
Characteristics of Units	Total Cooling Capacity / Sensible Cooling Capacity(22℃/50%)	kW	39.4/36.0			
	Total Cooling Capacity / Sensible Cooling Capacity(24℃/17℃)	kW	40.0/36.1			
	Total Cooling Capacity / Sensible Cooling Capacity(24℃/45%)	kW	39.2/37.5			
	Total Cooling Capacity / Sensible Cooling Capacity(26℃/50%)	kW	42.5/38.0			
	Heating Capacity	kW	18			
	Rated Humidifying Capacity	kg/h	8			
	Air Flow Volume	m ³ /h	13000	12500	12500	
	External Static Pressure	Pa	0	100	100	
	Acoustic Noise of Indoor Units	dB(A)	68	70	70	
	Range of Temp. Controlling and Precision	17~28℃±1℃				
	Range of Humidity and Precision	40~60%±5%				
	Power Supply	380V 3N~ 50Hz				
Cooling System	Compressor	Type	Hermetic Scroll Type			
	Evaporator	Type	Inner Screw Thread Pipe with Hydrophilic Film Aluminum Fin			
	Condenser	Type	Inner Screw Thread Pipe with Hydrophilic Film Aluminum Fin			
	Refrigerant		R410A			
	Throttling Method		Electronic Expansion Valve			
Air Supply System	Indoor Unit	Fan	Type	Low Noise and Centrifugal External-rotor		
			Type of	Direct Drive		
		Air Filter	Type	Plate Filter (G4)		
Heating System	Heater	Type	Electric Heating			
Humidifying System	Humidifier	Type	Electrode Type			
		Control Mode	Automatic Control by Mainboard			
Indoor Unit	Indoor Unit Model		JKFD40C2/Na-M(I)	JKFD40QS2/Na-M(I)	JKFD40SX2/Na-M(I)	
	Dimension	W	mm	2480	2480	2480
		D	mm	810	810	810
		H	mm	2250	1950	1950
Net Weight		kg	725	660	660	
Outdoor Unit	Outdoor Unit Model		JKFD19/NaA-M(O)			
	Qty		Set	2		
	Condensing Fan	Type		Low Noise Axial Type		
		Type of Drive		Direct Drive		
	Noise		dB(A)	64		

	Dimension	W	mm	1080
		D	mm	1180
		H	mm	1040
	Net Weight		kg	100
Connection pipe	Liquid Refrigerant Pipe		mm×pcs	Φ16×2
	Gas Refrigerant Pipe		mm×pcs	Φ19×2
	Method of Connection			Flared-fitting Joint

Notes:

1. This unit was designed, manufactured and tested according to National Standard GB/T 19413-2010.
2. Ambient temperature when testing cooling capacity: dry-bulb temperature indoors is 24°C and wet-bulb temperature is 17°C; dry-bulb temperature of outdoor side: 35°C.
3. The noise value was tested in the semi-anechoic chamber but the actual value will be a little higher for the change of ambient temperature.
4. Refer to nameplate on the unit for parameters of the unit. And the unit is Subject to change without further notice.
5. The temperature range of running environment is between: -35°C~48°C。
6. All models above can realize modular operation.
7. If there is any special requirement, please contact us.

5. PERFORMANCE CORRECTION

5.1 Correction of Cooling Capacity

Under different indoor or outdoor ambient temperatures, the cooling capacity of the unit will be different. The below diagram can be reference when customer select models.

JKFD5XXX Cooling capacity correction for single-phase unit

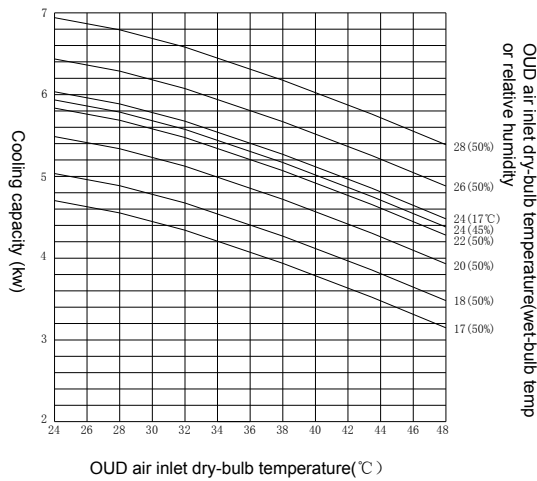

JKFD7XXX Cooling capacity correction for single-phase unit

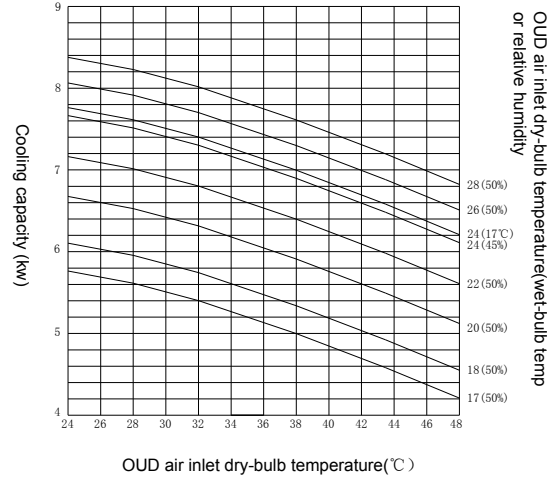

JKFD15XXX Cooling capacity correction

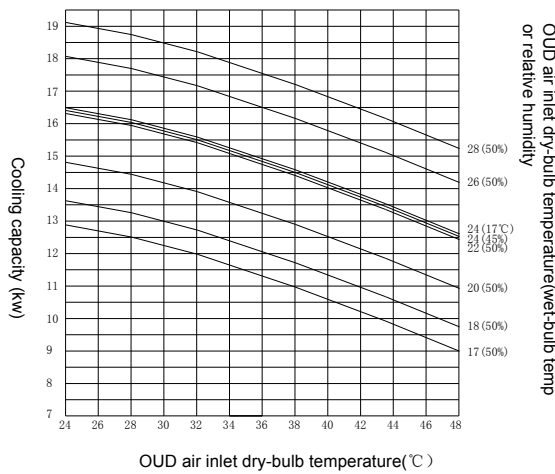

JKFD20XXX Cooling capacity correction

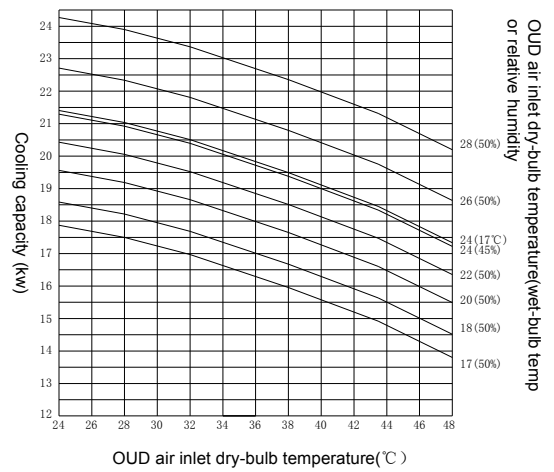

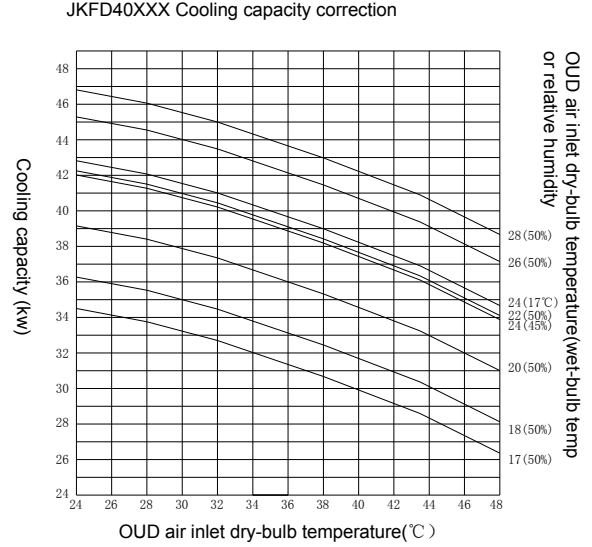
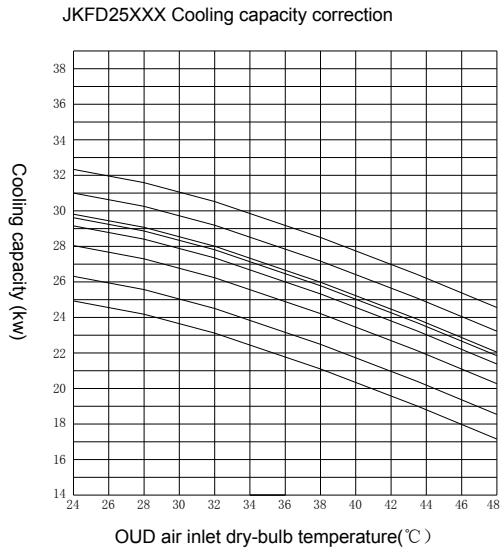

5.2 Coefficient of Correction Table for Various Conditions of Installation

The cooling capacity can be affected by the long connecting pipe, as well as the high drop between outdoor and indoor units. The below is the reference for coefficient of correction of cooling capacity.

Equivalent Pipe Length		Coefficient of Correction for Cooling Capacity									
		5m	10m	15m	20m	25m	30m	35m	40m	45m	50m
High Drop for Indoor Units Lowering than Outdoor Units	0m	1.0	0.98	0.96	0.94	0.92	0.9	0.89	0.88	0.87	0.86
	5m	1.0	0.97	0.95	0.93	0.91	0.89	0.88	0.87	0.86	0.85
	10m	-	0.96	0.94	0.92	0.9	0.88	0.87	0.86	0.85	0.84
	15m	-	-	0.93	0.91	0.89	0.87	0.86	0.85	0.84	0.83
	20m	-	-	-	0.9	0.88	0.86	0.85	0.84	0.83	0.82
	25m	-	-	-	-	0.87	0.85	0.84	0.83	0.82	0.81
	30m	-	-	-	-	-	0.84	0.83	0.82	0.81	0.8
High Drop for Indoor Units Higher than Outdoor Units	0m	1.0	0.98	0.96	0.94	0.92	0.9	0.88	0.87	0.86	0.85
	5m	1.0	0.97	0.95	0.93	0.91	0.89	0.87	0.86	0.85	0.84
	10m	-	0.96	0.94	0.92	0.9	0.88	0.86	0.85	0.84	0.83

The relative equivalent length of elbow and oil loop

Outside Diameter of Connecting Pipe(mm)	Elbow (m)	Oil Loop (m)
Φ9.52	0.2	1.4
Φ12	0.25	1.8
Φ16	0.3	2
Φ19	0.35	2.4
Φ22	0.4	2.8

Note: The equivalent pipe length equals the length of straight pipe plus the equivalent length of elbow and oil loop.

6. Installation of the unit

6.1 Installation Diagram of the Complete Unit

The complete unit consists of outdoor unit and indoor unit, which is shown as below:

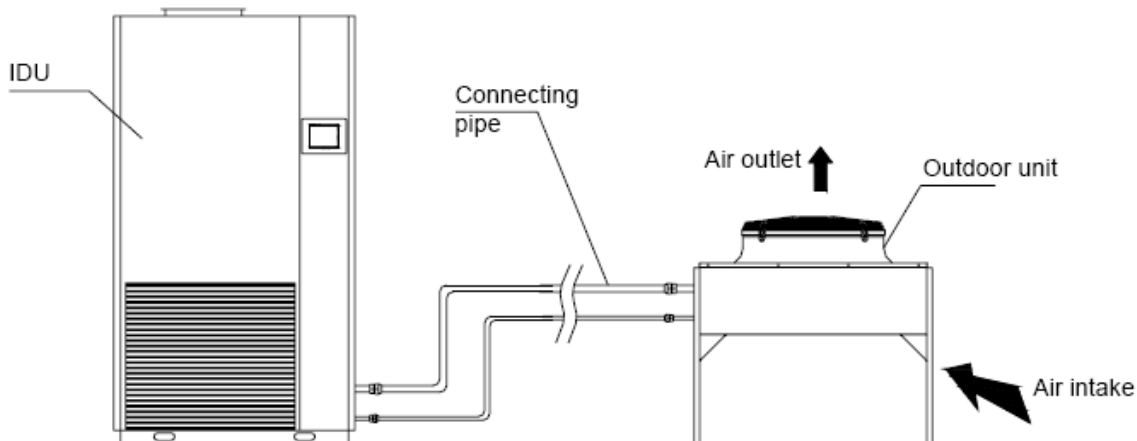

6.2 Outline Dimension of the Unit

6.2.1 Indoor Unit

◆ Outline Dimension of JKFD5 and JKFD7 Series (Direct Air Supply)

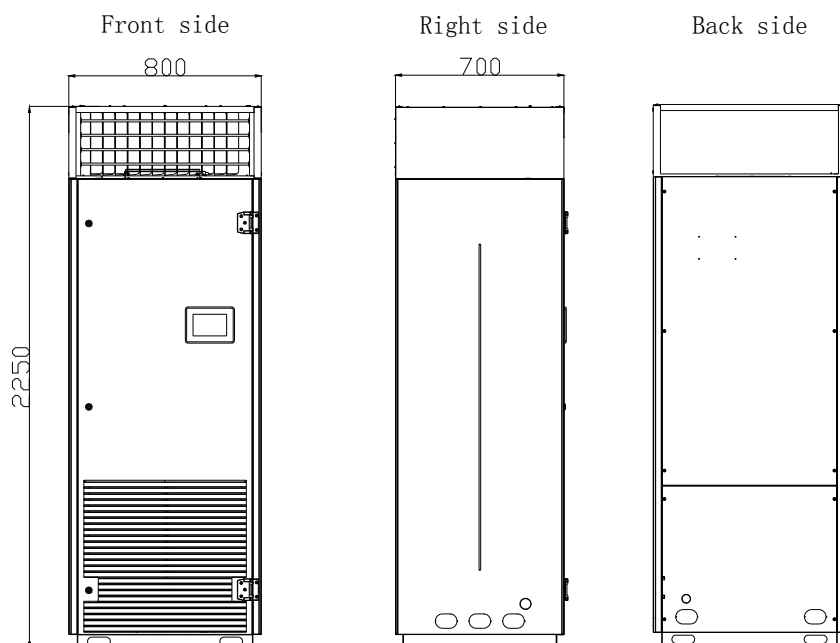

(The picture is for a reference only and the actual item is the standard. Unit: mm)

◆ Outline Dimension of Indoor units of JKFD5 and JKFD7 Series (Top Air Outlet)

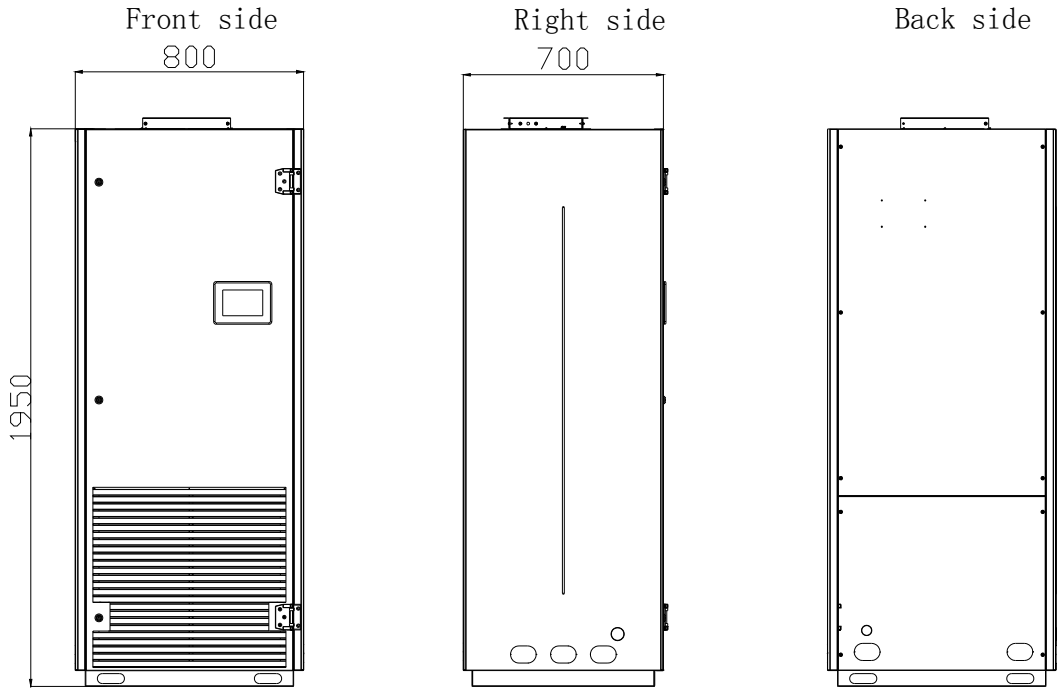

◆ Outline Dimension of Indoor Units of JKFD15 and JKFD20 Series (Direct Air Supply)

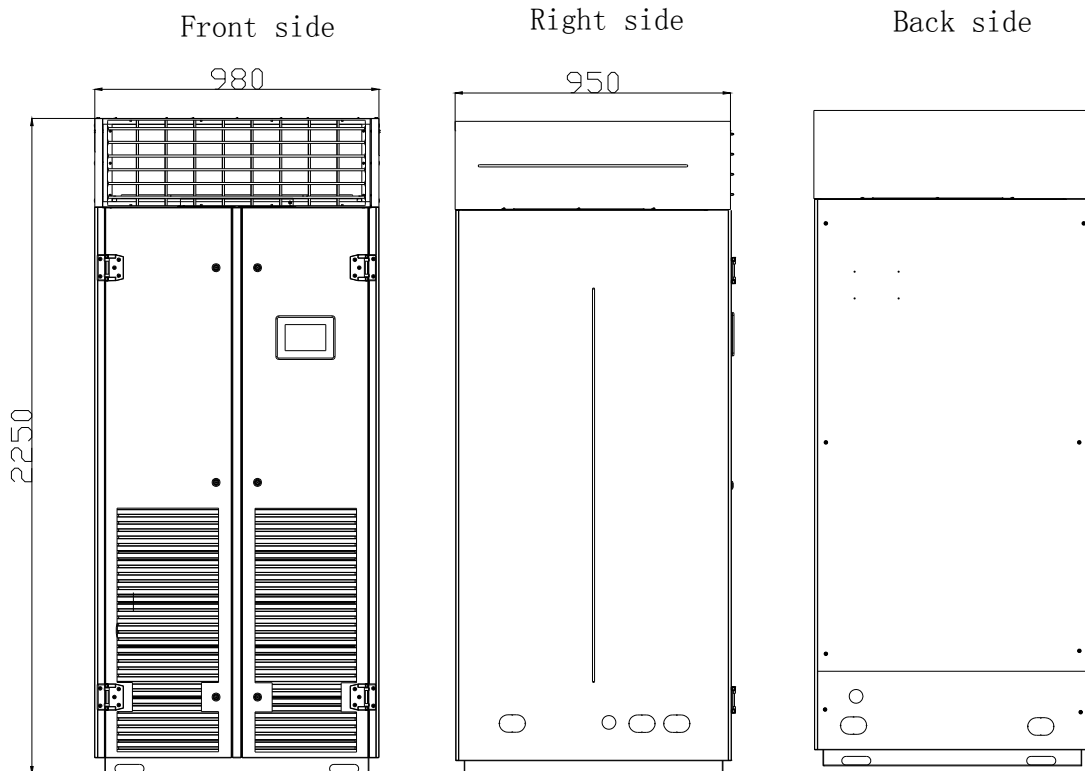

◆ Outline Dimension of Indoor Units of JKFD15 and JFKD20 Series (Top Air Outlet)

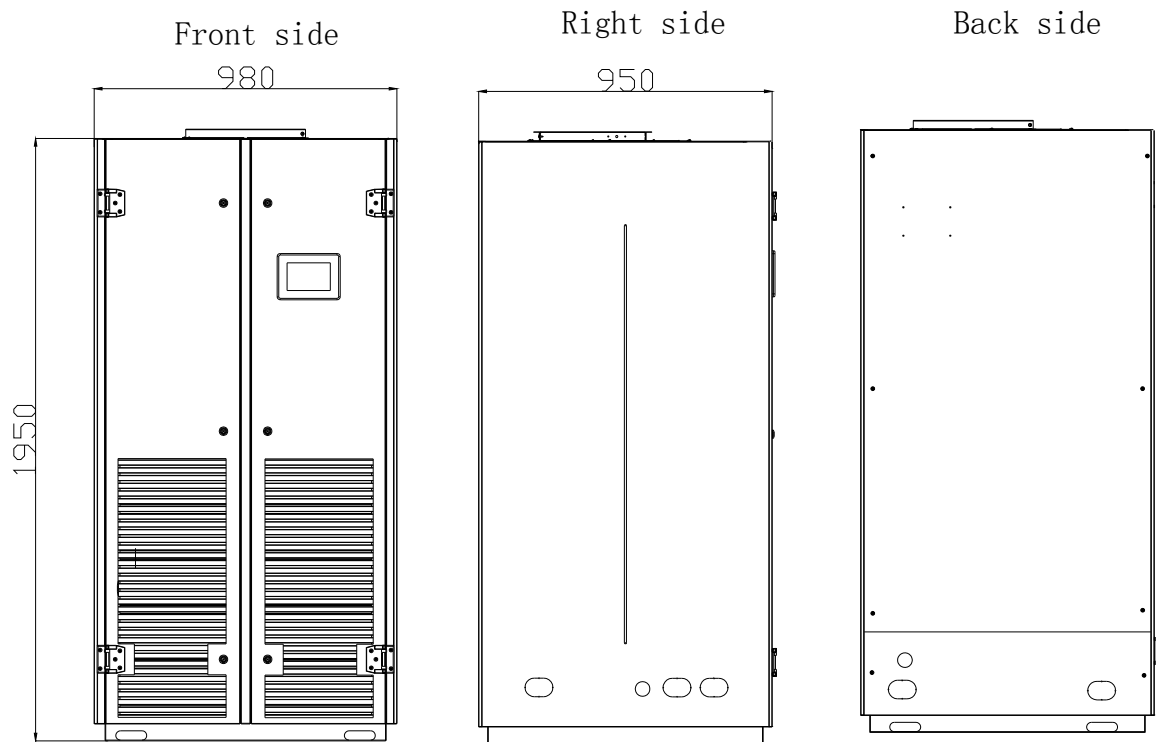

◆ Outline Dimension of Indoor Units of JKFD25 Series (Direct Air Supply)

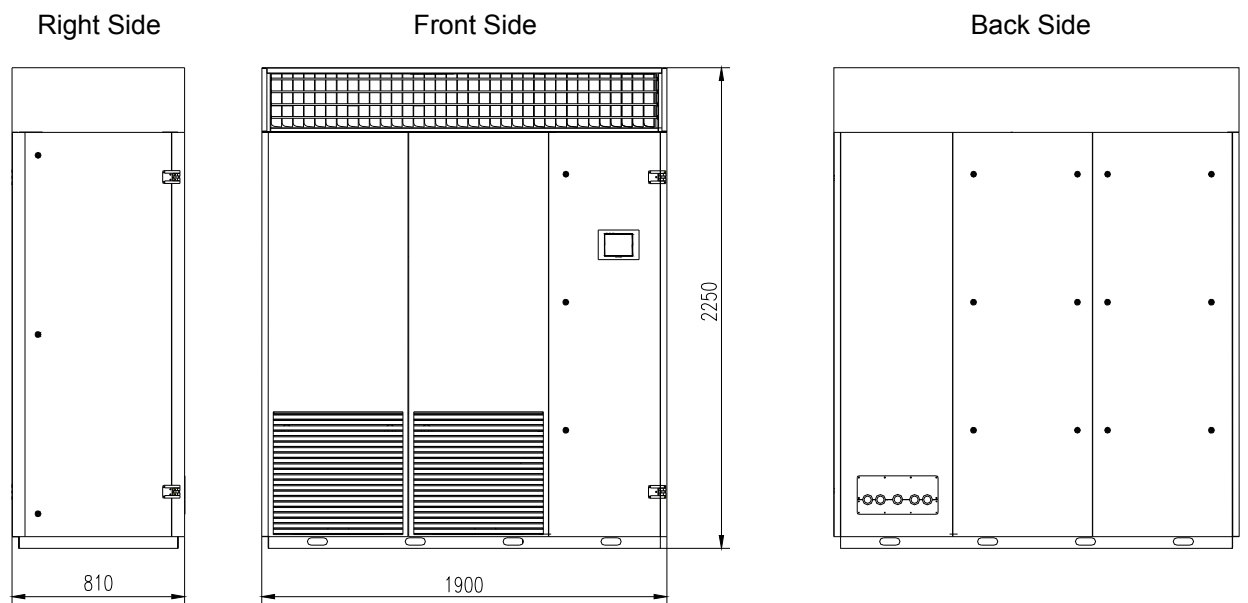

◆ Outline Dimension of Indoor Units of JKFD25 Series (Top Air Outlet)

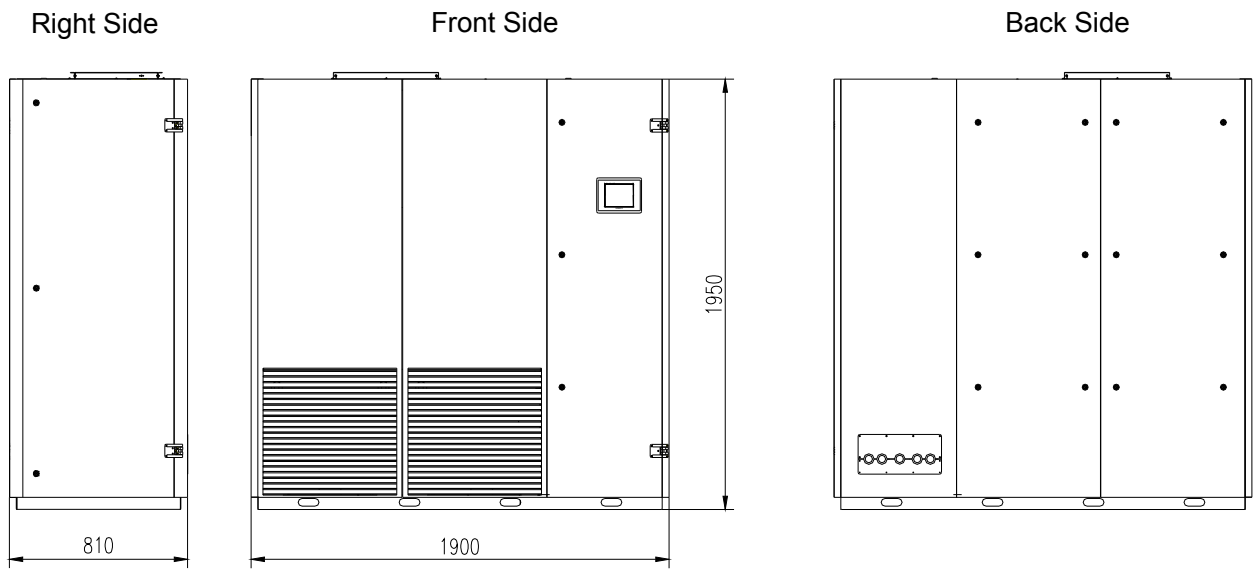

◆ Outline Dimension of Indoor Units of JKFD25 Series (Bottom Air Outlet)

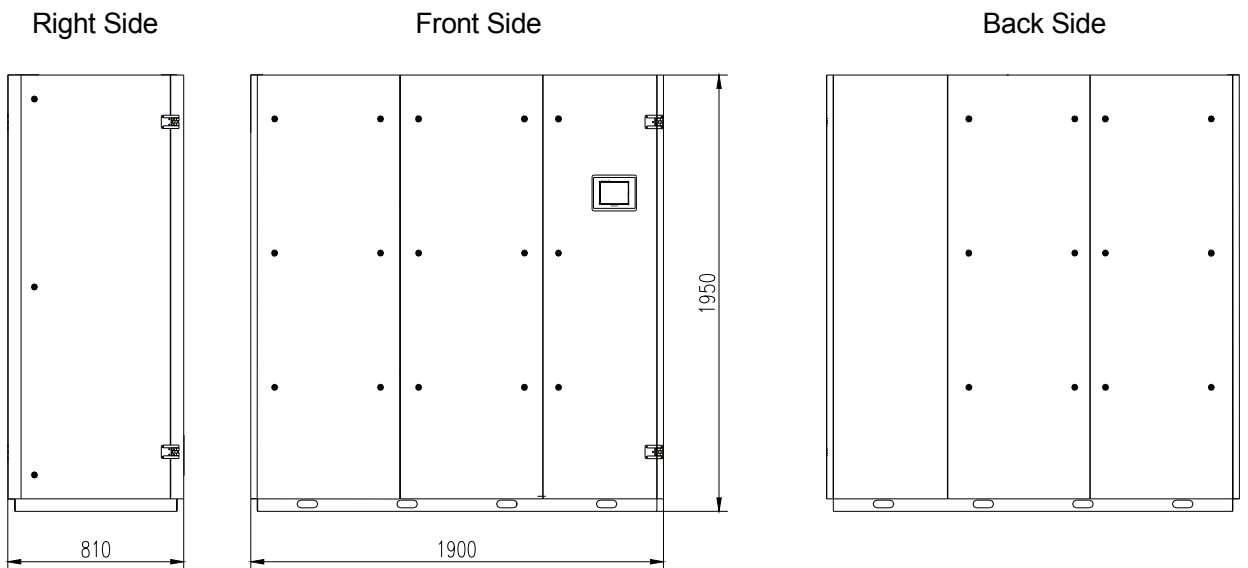

◆ Outline Dimension of Indoor Units of JKFD40 Series (Direct Air Supply)

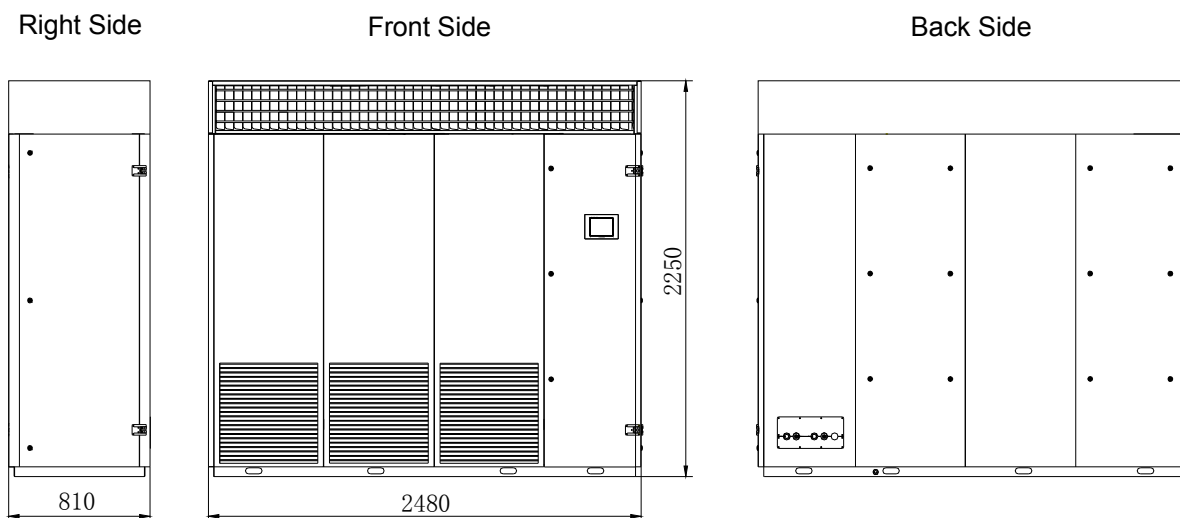

◆ Outline Dimension of Indoor Units of JKFD40 Series (Top Air Outlet)

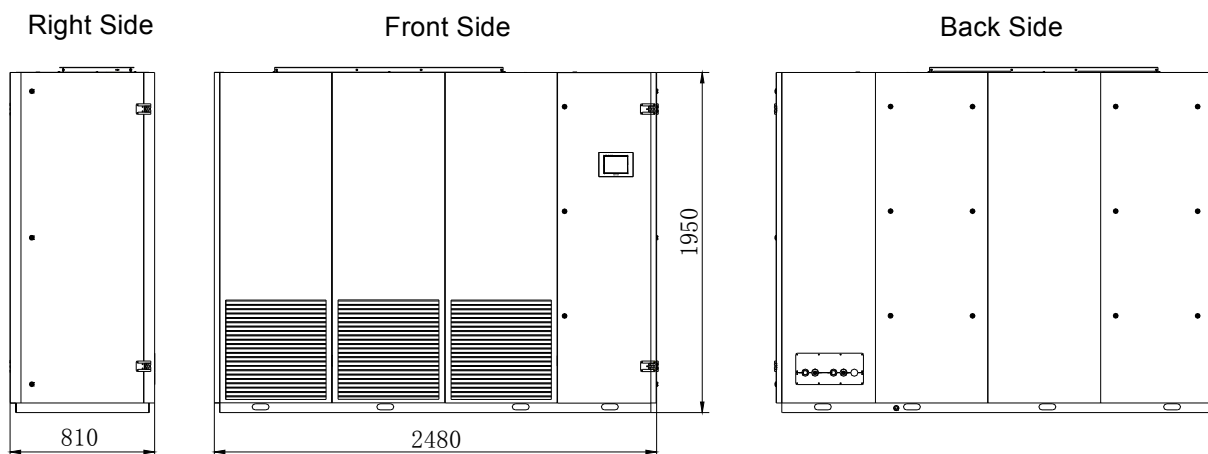

◆ Outline Dimension of Indoor Units of JKFD40 Series (Bottom Air Outlet)

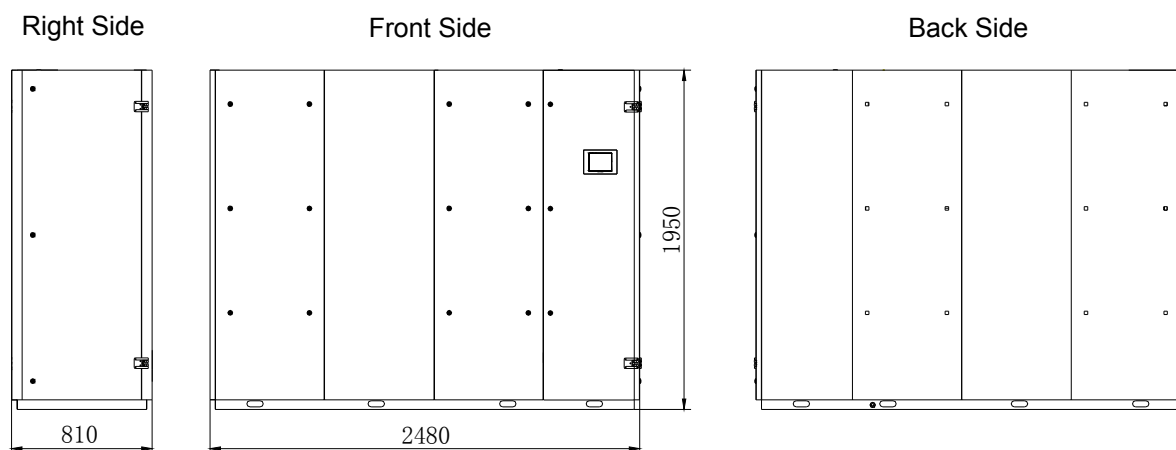

6.2.2 Outdoor Unit

◆ Outline Dimensions of JKFD5P/Na-E(O) and JKFD7P/Na-E(O)

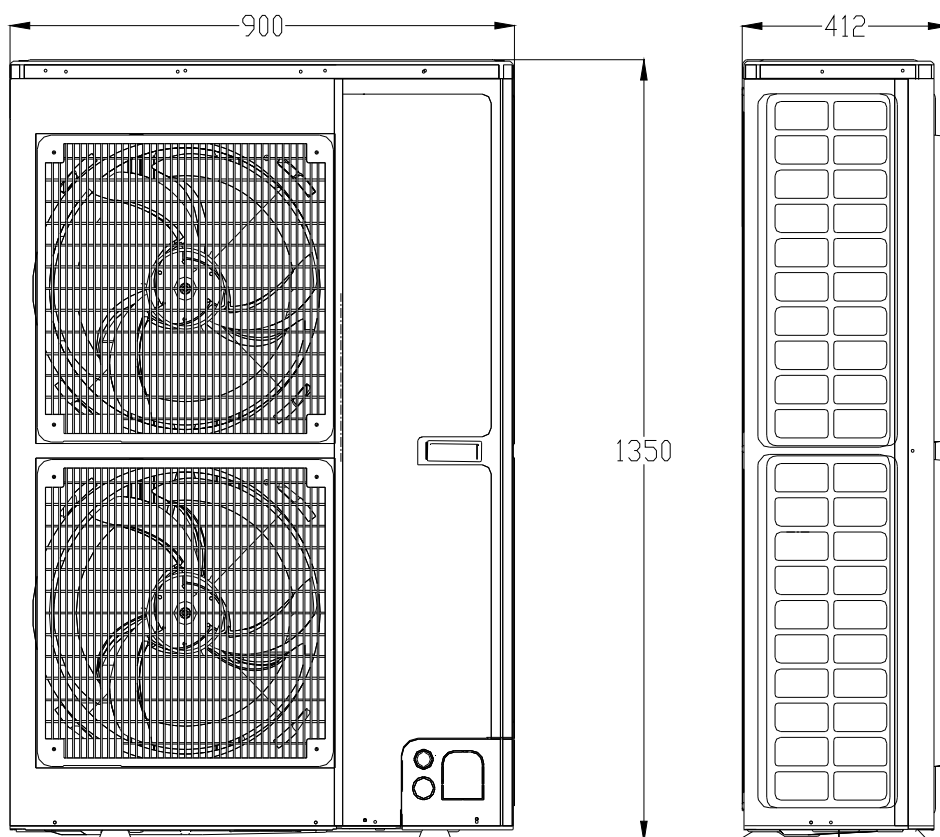

(The picture is for a reference only and the actual item is the standard. Unit: mm)

◆ JKFD15P/Na-M(O)、JKFD20P/Na-M(O)

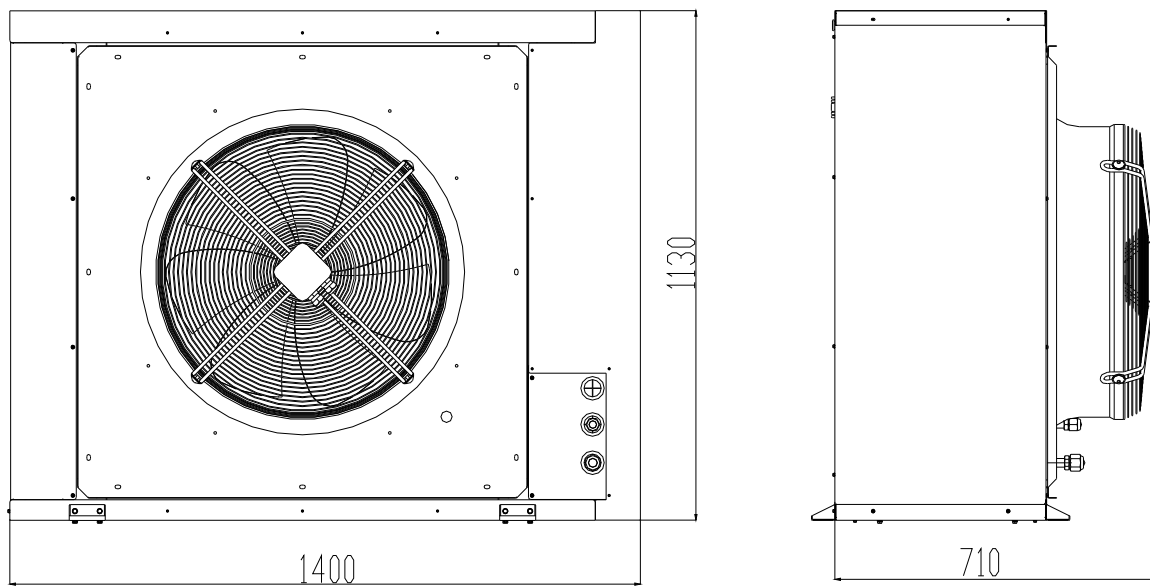

◆ JKFD13/NaA-M(O)

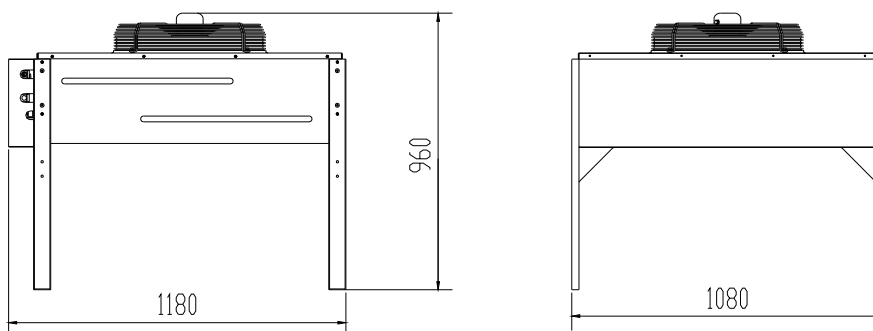

◆ JKFD19/NaA-M(O)

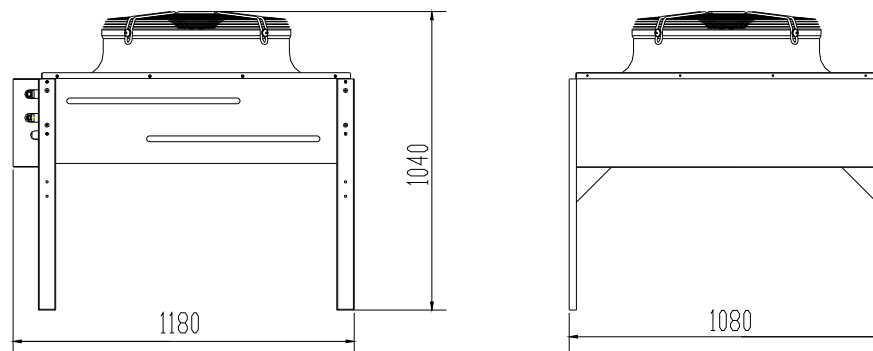

6.3 Installation Dimension and Space

6.3.1 The Installation of Indoor Unit

◆ Direct Air Supply (with cowl)

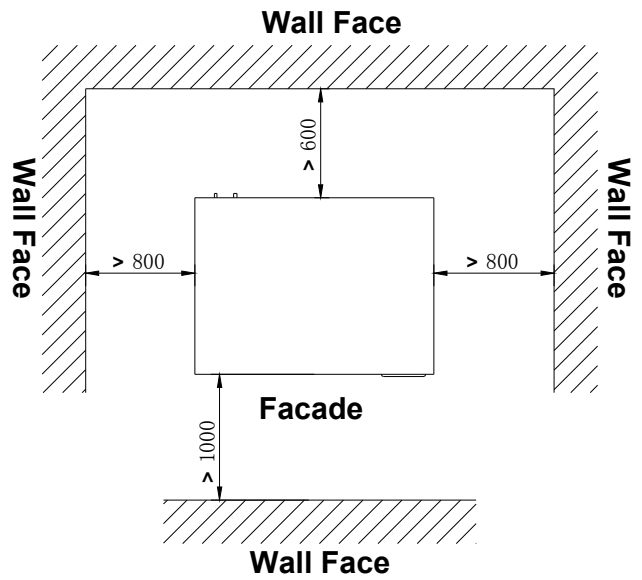
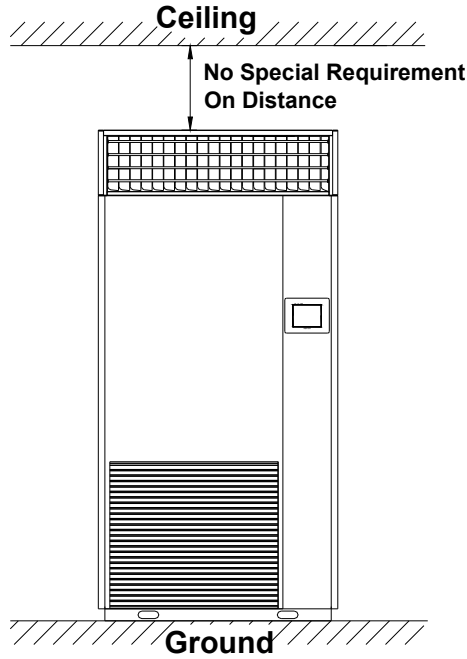

◆ Front Air Intake and Top Air Discharge (connecting with air duct)

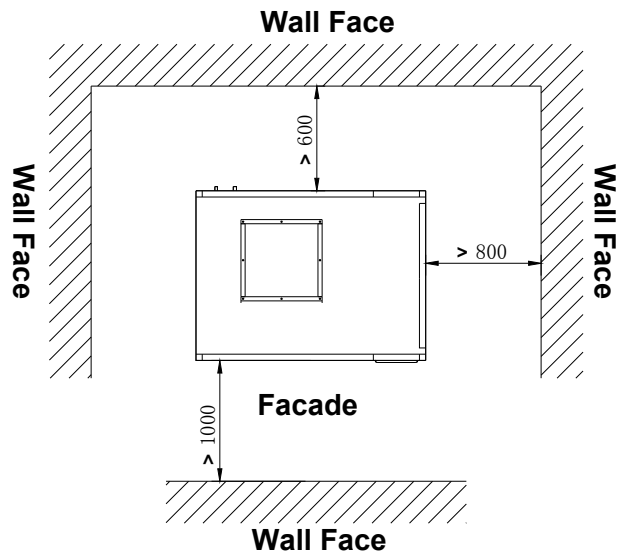
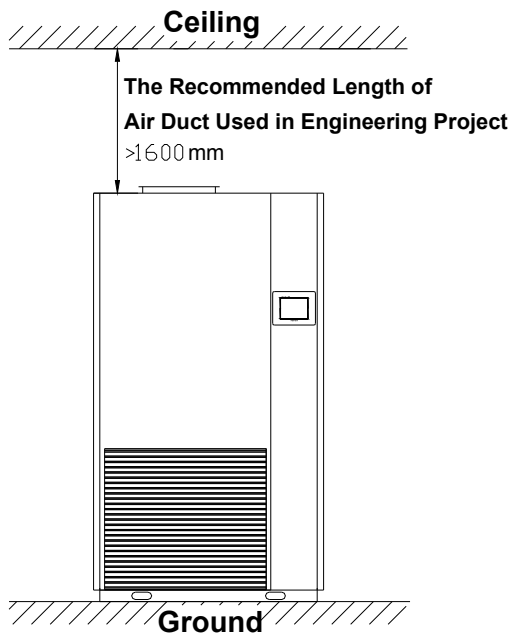

The Flange Size of Air Outlet on Top of the unit

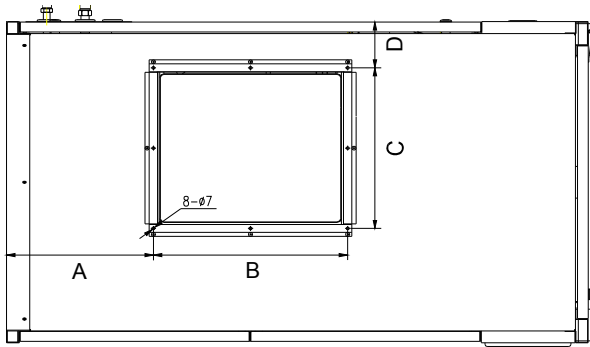

Model	A	B	C	D
JKFD5QSR/Na-E(I)	246	318	286	131
JKFD7QSR/Na-M(I)	246	288	276	152
JKFD15QSR/Na-M(I)	306	368	363	140
JKFD20QSR/Na-M(I)	260	461	405	108
JKFD25QS2/Na-M(I)	384	459	403	117

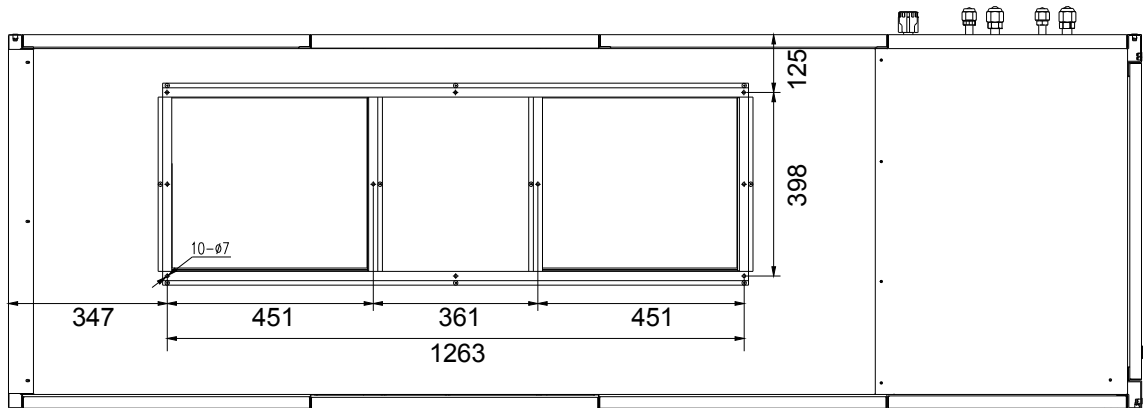

JKFD40QS2/Na-M(I)

◆ Top Air Intake and Bottom Air Discharge

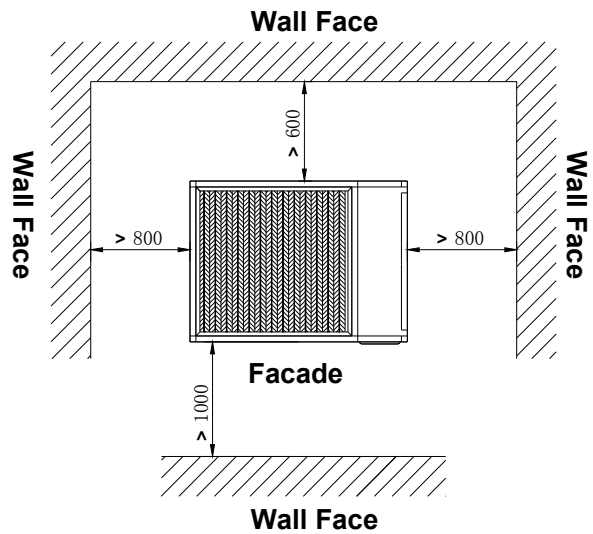
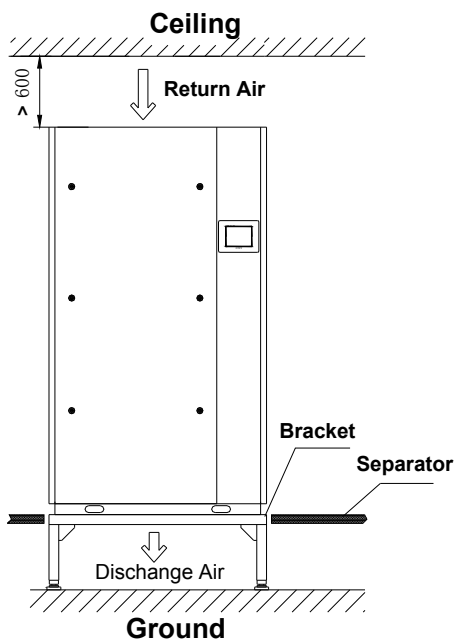

6.3.2 Installation of Outdoor Unit

◆ Disassembly of Outdoor Unit

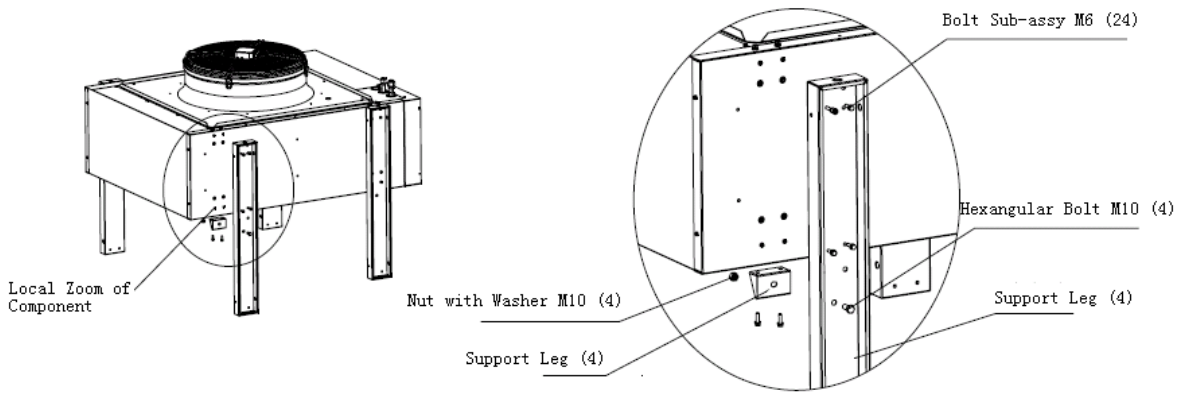
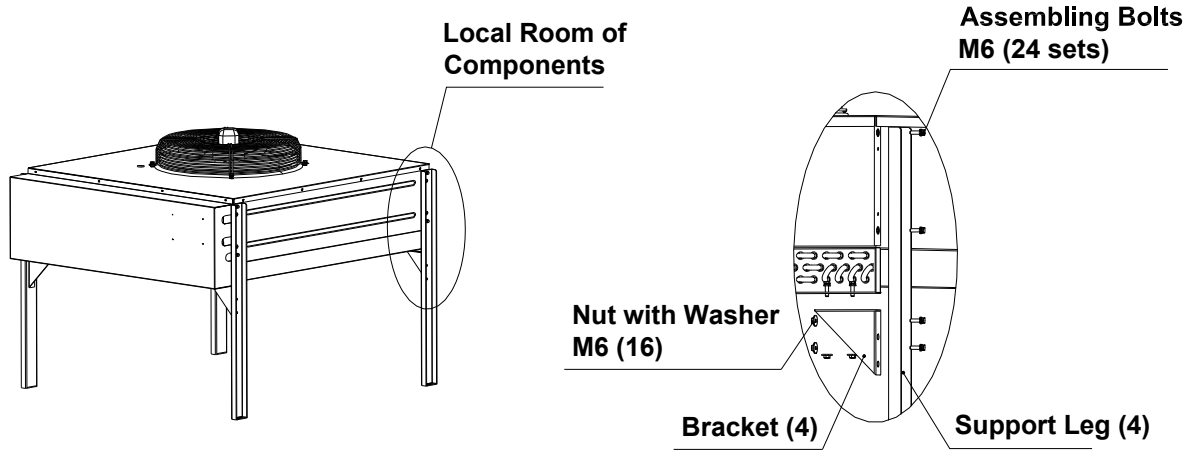

Disassembly Diagram of Horizontal Installation

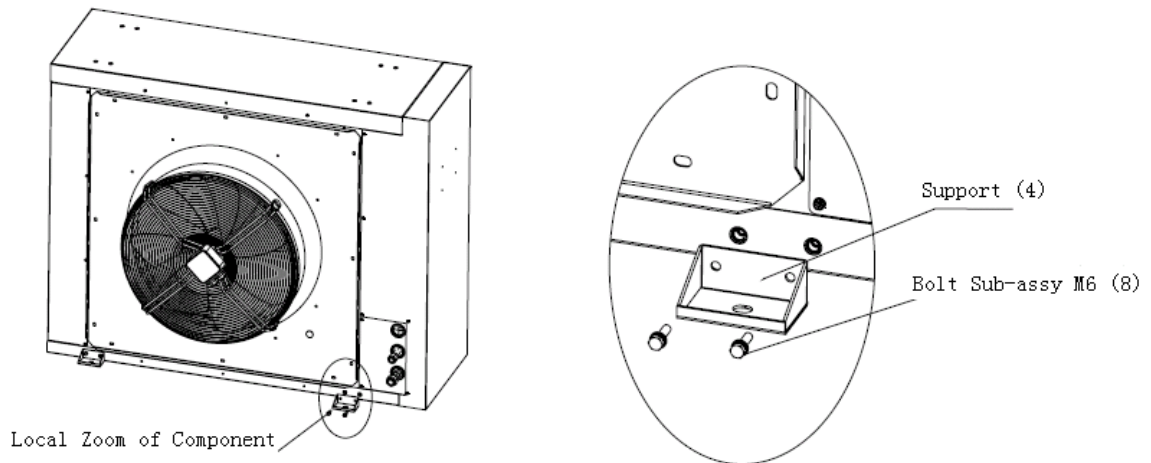

Disassembly Diagram of Vertical Installation

◆ Mounting Hole on Base

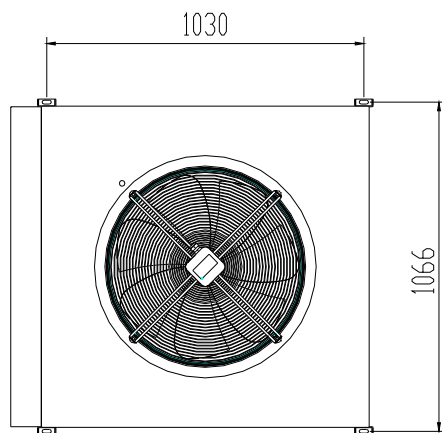

JKFD13/NaA-M(O)、JKFD19/NaA-M(O)

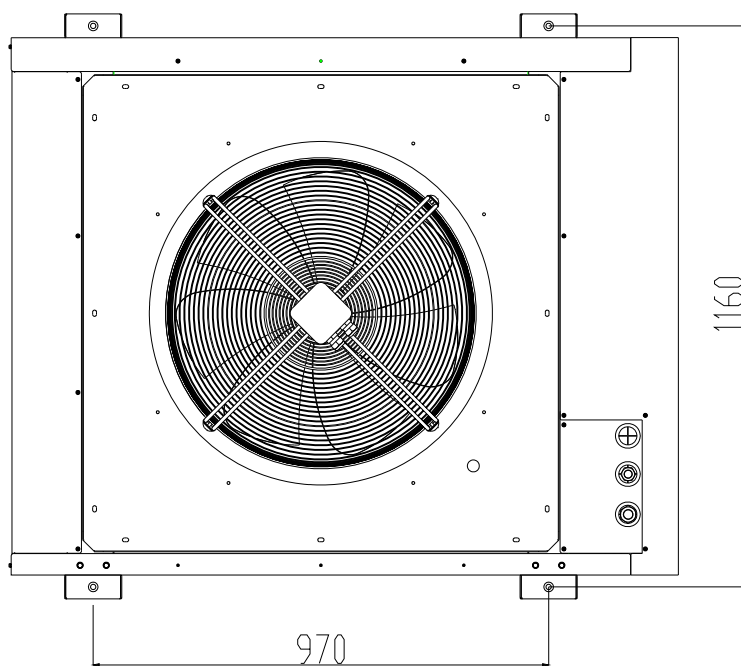
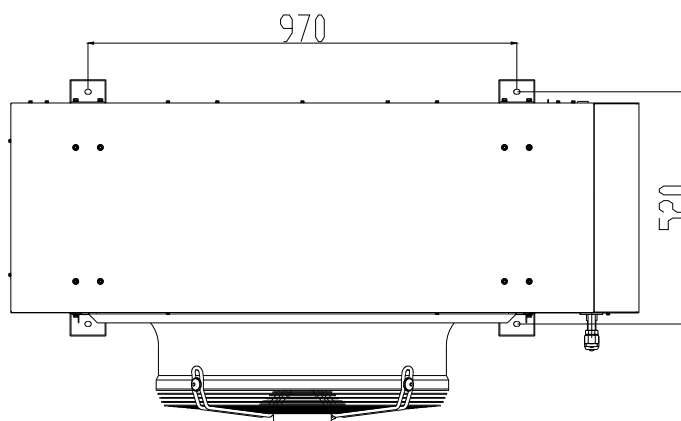

JKFD15P/Na-M(O)、JKFD20P/Na-M(O)

◆ Installation of Single Unit

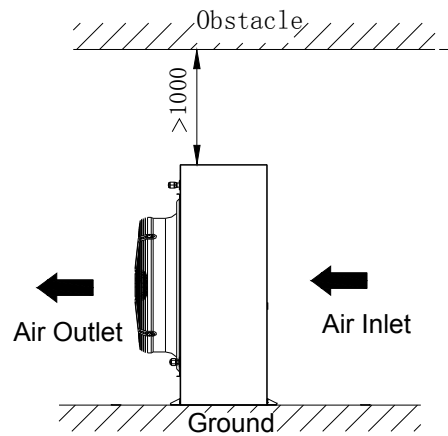
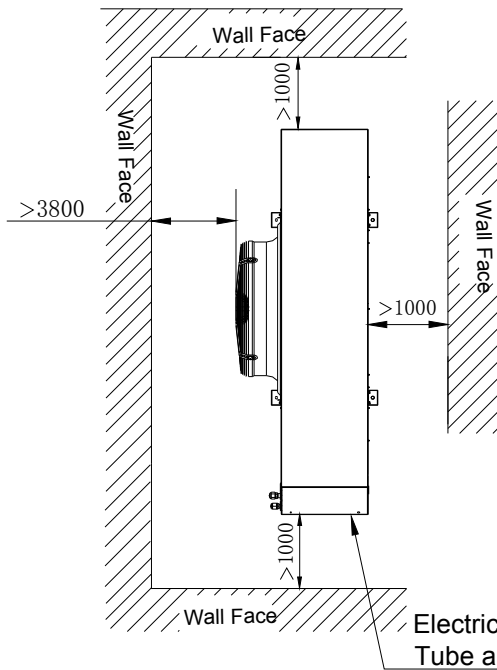
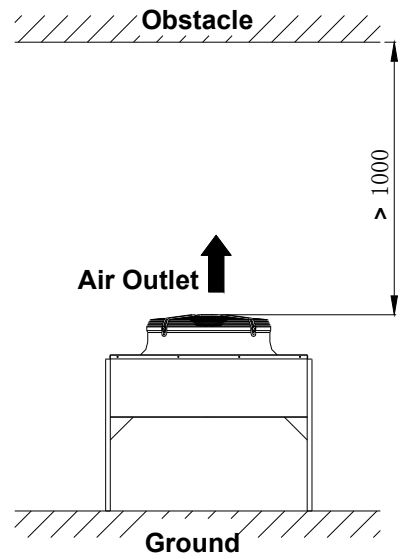
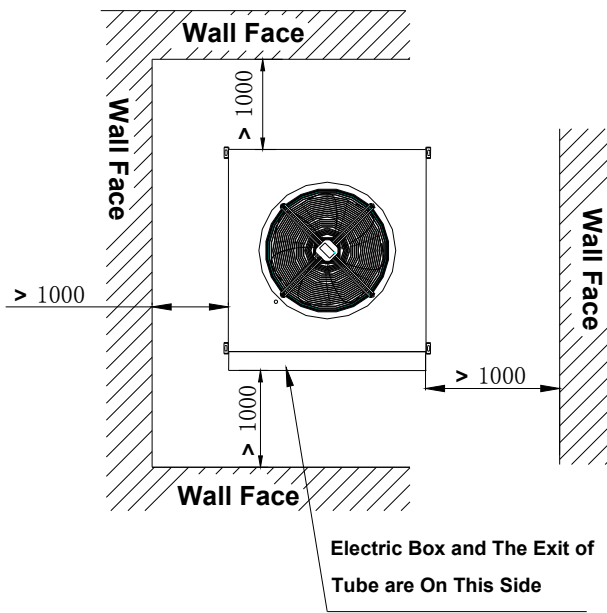

Vertical Installation of Single Unit

◆ Parallel Installation of Multi-units

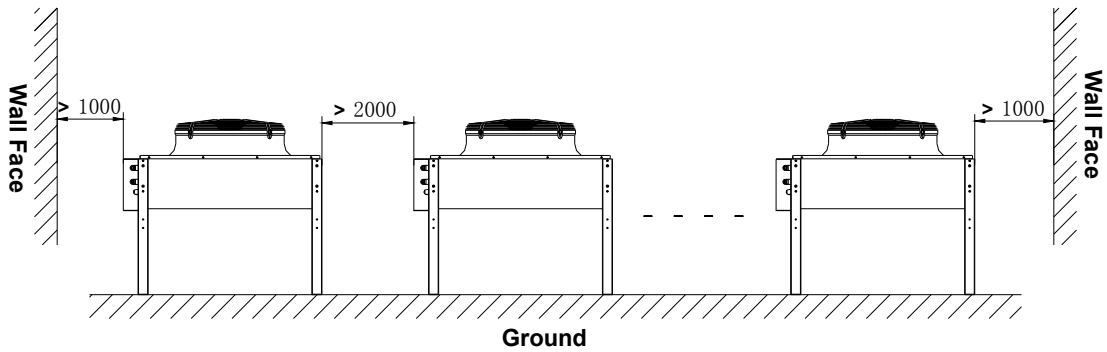

Horizontal Installation of Multiple Units

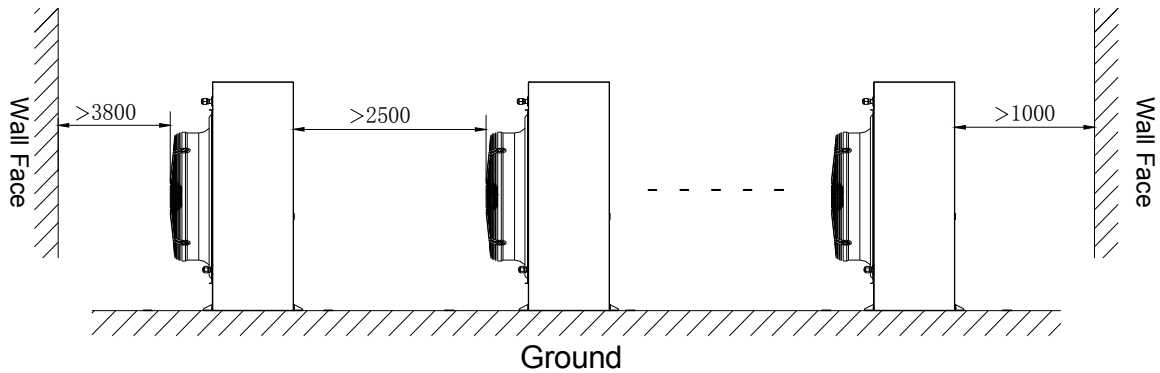

Vertical Installation of Multiple Units



Caution!

1. Intense magnetic field, high saline and alkaline land, the sites of high acid or extreme voltage instability are not suitable for the unit.
2. Make sure that the way of moving in is correct in case any damage to the unit or any danger occurred.
3. Confirm whether the installation base is secure and when the unit is installed on the metal part of a building, electric insulation and complying with relative technology standard have to be confirmed.
4. Confirm the site of installation is far away from the flammable, explosive Substance in case any explosion or fire hazard caused by the leak of them.

6.4 Requirements of Installation

Produced in the strict quality management system of our company, tested strictly, and

installed, debugged, operated as well as maintained according to this manual, the unit can work in proper state whose working life can also lengthen. In order to ensure the normal running and prevent the malfunction of the unit, the installation must be executed by experienced technicians with the knowledge of air-conditioner. And also, this part of the manual must be read carefully before installation.

For good running of the unit, the installation has to comply with the following rules

6.4.1 Requirements of Installation for Indoor Unit

(1) The refrigerants have been filled in indoor units before outgoing. Move and installation shall be cautious and the inclination pitch cannot be greater than 45°, let alone inversion.

(2) Installation of the unit shall completely meet the requirements of heat exchange and space for repairing, and also shall take the convenient pipes connection between indoor and outdoor units into account.

(3) Don't install the unit in the place with corrosive gas, intensive dust, salt mist, oily fume and the extreme wet site.

(4) Don't install the unit in places that store the flammable, explosive Substance or leak the flammable, explosive gas.

(5) The location of the unit has a great influence on the ambient temp. and humidity of the machinery room. On the permission of the project, it shall be close to the spot of the maximum loading as much as possible and shall make sure that the return air can be unobstructed and the supply air can be even distributed.

(6) The unit shall be installed on the flat concrete foundation with the steel flatbase on which the rubber sheet of 15mm thickness is paved.

(7) Make sure that the ground is horizontal and the inclination pitch cannot be greater than 1°.

(8) Make sure that the drainage of condenser water and humidifier are smooth. Due to the possibility of high temperature (maximum temp. could be 100°C) of humidifier's drain water, shall pay attention to the security of the drainage.

(9) When the unit is installed on the bracket whose height is adjustable (the type of lower supply air outlet), the unit and the bracket shall be fixed by bolts and the joint face shall be paved with the rubber shock absorption mat.

6.4.2 Requirements of Installation for Outdoor Unit

(1) The refrigerants have been filled in outdoor unit before outgoing. The move and installation shall be cautious.

(2) Installation of the unit shall completely meet the requirements of heat exchange and

space for repairing, and also shall take the convenience of pipes connection between indoor and outdoor units into account.

(3) The outdoor unit shall be installed and securely fixed in the stable and firm supporting surface outside the building

(4) The outdoor unit and the indoor unit should be close to each other as much as possible in order to reduce the length of cooling pipes and the quantity of elbows.

(5) Don't install the outdoor unit under the window or between close buildings in order to prevent the normal running noise from interior.

(6) Choose the airy place to install the unit and the distribution of air outlet and air inlet can be unobstructed so that the unit can inhale and exhale enough non cyclical air.

(7) Don't install the unit in the place with flammable and explosive Substance, as well as polluted air, including intensive dust, salt mist, etc.

(8) Make sure that the ground is horizontal and the inclination pitch cannot be greater than 1°.

6.4.3 Requirements of Connection between Indoor units and Outdoor Units

(1) The standard length of pipes connected outdoor units and indoor units is 10m. When the length of the pipe is less than or equal to 10m, there is no need for extra refrigerants. However, if it is over than 10m (Subject to the liquid pipe), the refrigerants and lubricant should be added. The specific charge is as follows:

Model \ Item	Charge volume(kg) of refrigerants for every 1 m longer of connecting pipe	Charge volume (kg)of lubricants for every 10 m longer of connecting pipe	Notes
JKFD5DXXX	0.054	0.1	Use R410A refrigerant and POE lubricant
JKFD7XXX			
JKFD15XXX	0.11	0.2	
JKFD20XXX	0.17	0.2	
JKFD25XXX	0.11×2	0.2×2	
JKFD40XXX	0.17×2	0.2×2	

(2) When the location of the outdoor unit is higher than that of the indoor unit, the altitude intercept shall less than 30m while the location of the outdoor unit is lower than that of the indoor unit, the altitude intercept shall less than 10m (try best to avoid such situation which easily affects the cooling capacity of the unit). Total length of pipes cannot exceed 30m. When the length of vertical gas pipes between indoor units and outdoor units is greater than 10m, set a oil loop every 10m whose bending radius

should be small as much as possible but cannot less than 1.5 times of diameter of the pipe. If the installation length exceeds the above requirements, please consult the manufacturer. Long connecting pipe accessory are needed.

- (3) The connecting pipe is copper pipe and its specification is Subject to the performance form. Before connection, the copper pipe must be cleaned and dried.
- (4) After welding of connecting pipes, then the stain removal (blowing down welding slag and impurities), it can be welded with the indoor unit and outdoor unit.
- (5) After connection of the pipe, it shall be filled with nitrogen to detect the leakage or resort to vacuum pump and pressurization to detect leakage.
- (6) When the pipe connection of outdoor units and indoor units has been finished, the pipe should be in the process of thermal insulation.

6.4.4 Connection Requirements of Infrared Humidifier

(1) The infrared humidifier shall connect with water pipe. For the convenience of maintenance, one filter or check valve shall be installed in the water inlet pipe.

(2) A D20 PPR pipe with G1/2 external thread connection at its end is reserved in the unit for the water inlet pipe of infrared humidifier. Please take out the copper thread joint in the accessories bag for connection. Other connection way can be selected in engineering, but the connection must be sealed to prevent water leakage.

(3) In the position of main pipeline with pressure higher than 700kPa, a pressure reducer shall be installation. The pressure of main pipeline shall be ranged from 100kPa to 700kPa. For the position of main pipeline with pressure lower than 100kPa, a water-collecting groove and water pump system shall be applied.

6.4.5 Vacuumization and Refrigerant Filling

(1) Refrigerants have been charged in the outdoor and indoor units before outgoing.

Whether extended pipes for installation should be charged with refrigerants and how much refrigerants are needed, which are decided by the length of refrigerant pipes.

(2) Make sure that the liquid valve and air valve are shut down.

(3) Pump the air inside of connecting pipes from the air valve and the liquid valve of indoor units, which is as shown in the following figure.

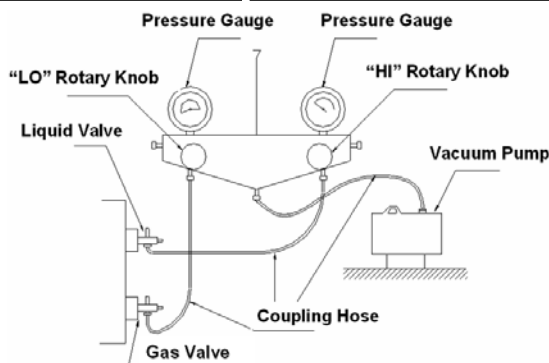

- (4) Make sure that there is no leakage. When the compressor has stopped, the required amount of R22 refrigerants should be added into the valves of the indoor. If refrigerants cannot be added into required amount quickly due to the increased pressure in the pipe, keep the unit ON, and charge refrigerants into the fluorine-feeding nozzle in the inhalation tube of the indoor unit.

6.4.6 Installation of Drain Pipe

- (1) In order to drain easily, the outlet of drain pipes should be lower than the base surface of the unit at least 200mm.
- (2) Due to the possibility of high temperature of drain water of humidifier, please adopt the materials with high-temperature resistance for connection in order to drain out water directly. In order to prevent leakage of electricity, the beginning connection of drain pipe should be rubber or other non-conducting plastic pipes

7. Electric installation

7.1 Electrical Installation

7.1.1 General Connection Diagram

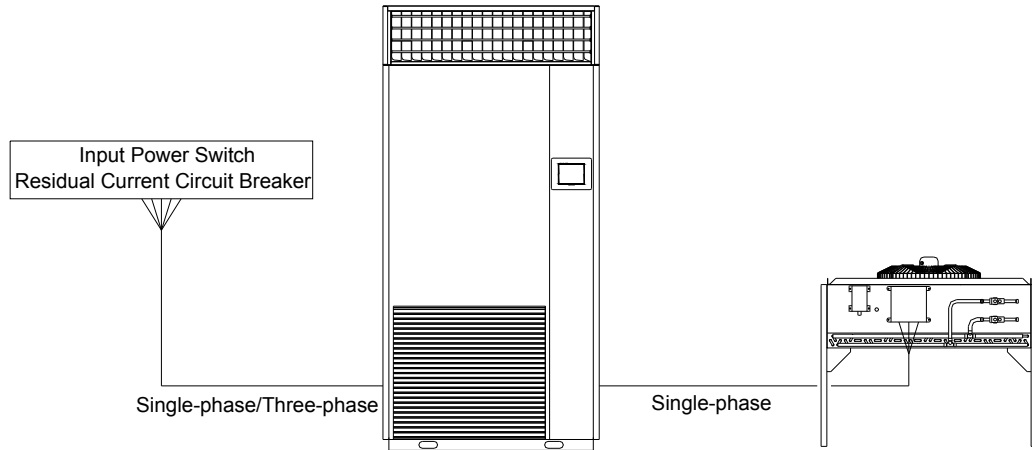

7.1.2 External Wiring Diagram

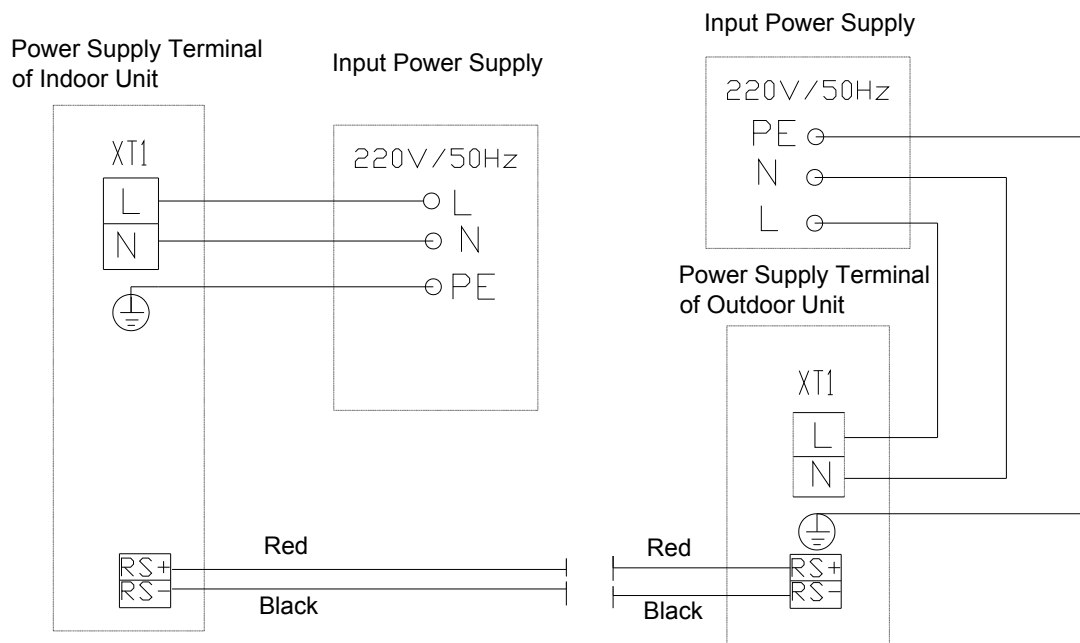

JKFD5XXX

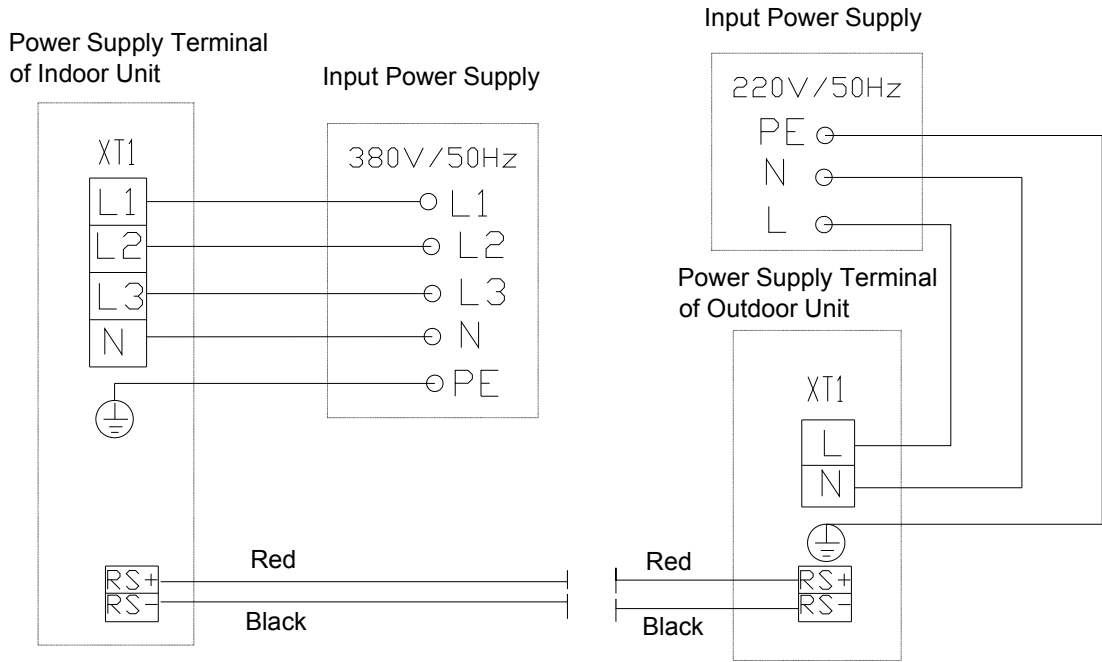

JKFD7XXX

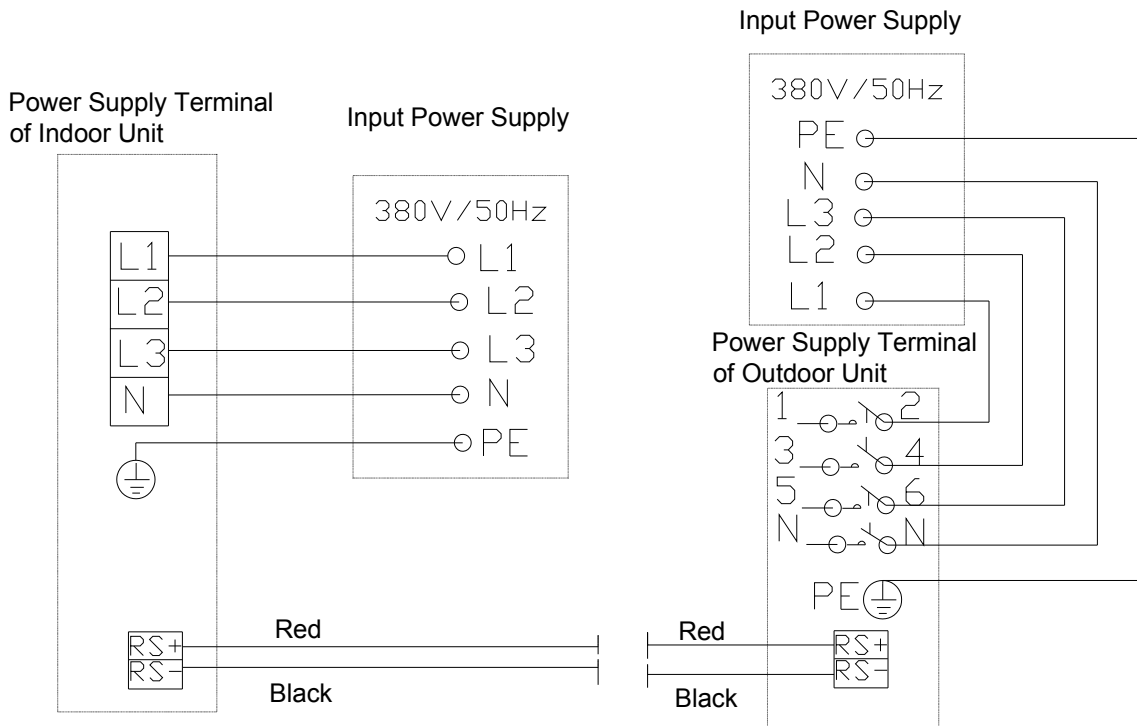

JKFD15XXX, JKFD20XXX

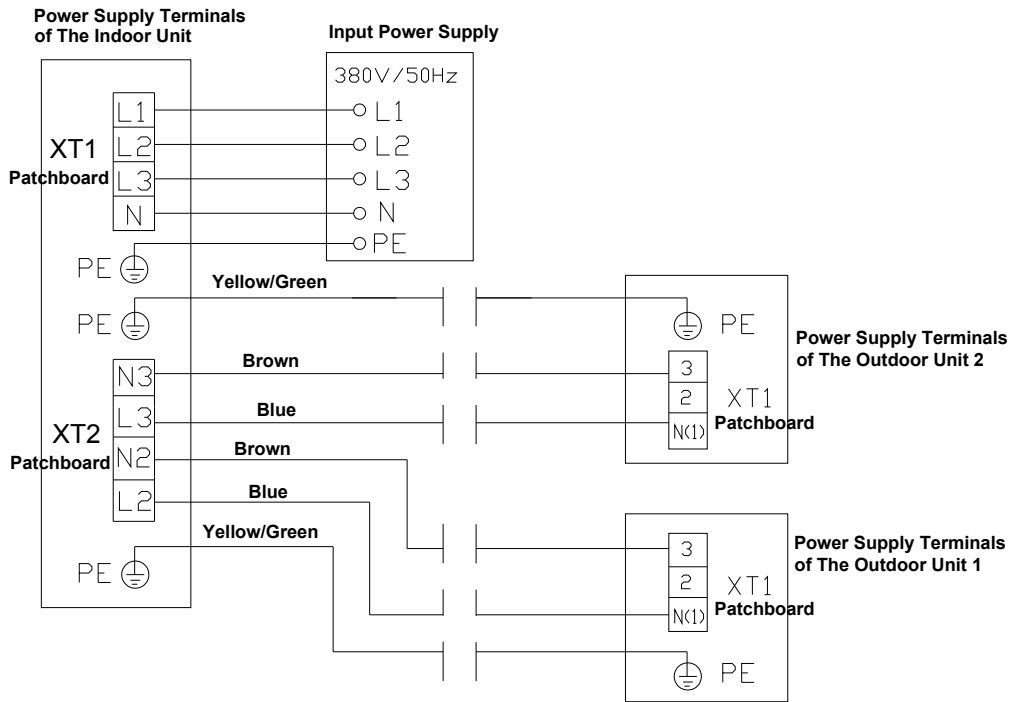

JKFD25XXX、JKFD40XXX

All Kinds of Warning Wiring Diagram

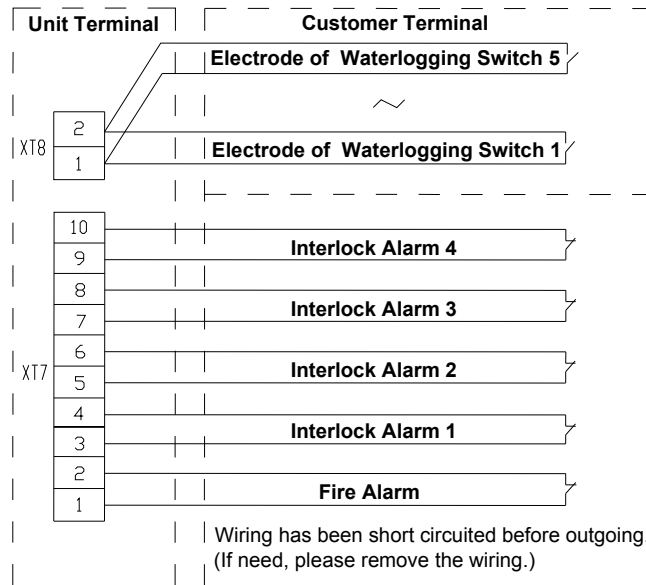

Caution: All electric installations have to be conducted by professional personnel in accordance with the local law, regulations and this manual.

7.1.3 Wiring Requirements

◆ Layout of Electric Wires

- (1) The layout should comply with related national regulations for wiring.
- (2) Rated voltage and dedicated power supply of the unit are required to apply.
- (3) Communication cable shall be shielded twisted pair line.
- (4) Power cord or communication cable shall be fixed to avoid the stress on supply terminals. Do not drag or pull the cable with force.
- (5) The diameter of power cord shall comply with requirements of this manual. Dedicated cables must replace the damaged power cord and communication cable in time.
- (6) All electrical installations have to be conducted by professional personnel in accordance with the local law, regulations and this manual.
- (7) Grounding should be reliable and performed by professionals on construction's specialized grounding device.
- (8) Air switch and leakage switch for the whole system have to be installed. The air switch should have the function of stopping the system from short circuit and overload.
- (9) Refer to the wiring diagram which pasted on the unit as guidance for wiring.

◆ Requirements of Connecting Electric Appliances

- (1) All operations for wiring must strictly comply with the wiring diagram of the unit.
- (2) Power supply of the unit must be equipped with air switch for general power supply by customers and conductor cross-section is selected according to the requirements on electrical wiring diagram of the unit.
- (3) Range of power supply voltage of the unit with three-phase source is 360~400V and unbalancedness degree of three-phase system cannot exceed 3%.
- (4) The unit applied three-phase source has equipped with reverse phase protection device. If phases are reversely connected, it cannot work.
- (5) Please connect wire strictly according to the wiring diagram.



Caution: the unit requires the reliable protective earthing. (There is earthing symbol in the electric cabinet of the unit )

◆ Earthing Requirements

(1) Since air conditioner is type I appliance, please do conduct reliable earth treatment.

The yellow-green wire inside unit is earth wire, which can not be used for other purpose and further not be cut off. Don't fix it with tapping screw to avoid electric shock.

(2) Earthing resistance should match requirements of National Standard GB17790 which is published by China government.

(3) Users' power must offer reliable earth terminal. Please don't connect earth wire to following places:

- ① Water pipe; ② Gas pipe; ③ Blowing pipe;
- ④ Other places that professional personnel consider unreliable.

7.2 Matching Form of Power Cord and Air Switch

Model	Power Supply	Air Switch Capacity (A)	Minimum Sectional Area (mm ²)	
			Earthed Cable	Power Cord
JKFD5XXX(I)	220V ~ 50Hz	63	10	10
JKFD5P/Na-E(O)	220V ~ 50Hz	6	1.5	1.5
JKFD7XXX(I)	380V 3N~ 50Hz	32	4	4
JKFD7P/Na-E(O)	220V ~ 50Hz	6	1.5	1.5
JKFD15XXX(I)	380V 3N~ 50Hz	40	6	6
JKFD15P/Na-M(O)	380V 3N~ 50Hz	16	1.5	1.5
JKFD20XXX(I)	380V 3N~ 50Hz	40	6	6
JKFD20P/Na-M(O)	380V 3N~ 50Hz	16	1.5	1.5
JKFD25XXX(I)	380V 3N~ 50Hz	63	16	16
JKFD13//NaA-M (O)	220V~ 50Hz	-	1.5	1.5
JKFD40XXX(I)	380V 3N~ 50Hz	100	25	25
JKFD19//NaA-M (O)	220V~ 50Hz	-	1.5	1.5

Note:

① Specifications of circuit breaker and power cord from the above form were taken according to the unit's biggest current;

② Specifications of cable from the above form were taken under the condition where multi-core cables, whose service ambient temperature is 30°C and tolerant temperature is

90°C (e.g. copper core cross-linked cable with PE insulation and PVC sheath), out-spread on the surface of slot (GB/T 16895.15); If condition changes, please adjust specifications according to national standard;

③ Specifications of circuit breaker is based on the working condition where ambient temperature of circuit breaker is 30 °C . If working condition changes, please adjust the specifications according to national standard.

II Control

1 Control of the Unit

1.1 General Control

When the unit is energized, the system starts to detect each part. If there is malfunction, malfunction code will be displayed and relevant procedure will be entered. If there is not malfunction, the unit will operate according to command from display panel. When the unit is started up, the unit will judge if there is auto operation command or manual debugging command from the display panel. If there is manual debugging command, the unit will operate at manual debugging mode. If there is malfunction during operation, the relevant procedure will be entered. If there is turning off command, the unit will enter turning off procedure.

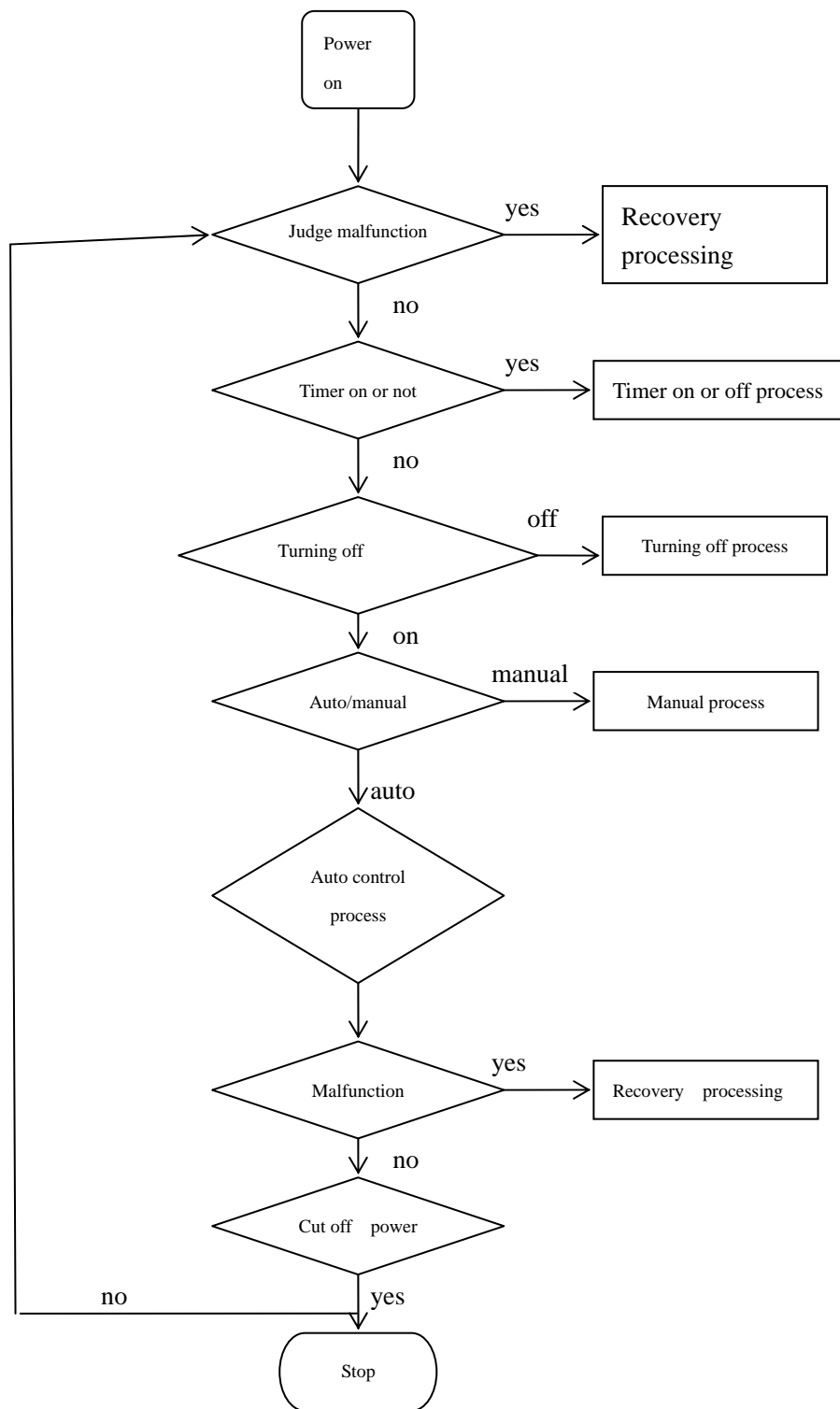

1.2 Introduction to Key Control Logic of the Unit

(1) Control of Indoor Fan

When pressing ON button or timer on is reached, the fan will operate in set time. When the unit is turned off or timer off is reached, indoor fan will be turned off in 3 minutes. Indoor fan shall operate earlier than other loads. If the indoor fan has malfunction, the complete unit will stop.

(2) Control of Compressor

When the unit operates, if ambient temperature is higher than set temperature or ambient humidity is higher than set value, the startup of the compressor will delay. If ambient temperature is lower than set value of the system, the compressor will stop operation. Startup and stop of the compressor shall conform to min operation time and min stop time. Control system will compare the accumulated operation time of two compressors. The compressor with less accumulated operation time will start first and the one with longer time will stop first.

(3) Control of Auxiliary Electric Heater

When the unit operates, if ambient temperature is lower than set value or fluctuation of temperature or humidity reaches the specified conditions for startup, electric heater will operate. When ambient temperature is higher than set value or fluctuation of temperature or humidity reaches the specified conditions for stop, electric heater will stop operation. Control system will compare the accumulated operation time of two electric heaters. The heater with less accumulated operation time will start first and the one with longer time will stop first.

(4) Control of Humidifier

When the unit operates, if ambient temperature is within the control range, and the humidity is lower than set value of the control of the system, the humidifier will be started. When ambient humidity is higher than set value, humidifier will be turned off. Control system will compare running current of humidifying and set current. When current of humidifying is lower than set value, feed valve will be turned on. When current of humidifying is higher than set value, feed valve will be turned off. Based on calculation of the continuous operation time and stop time of humidifier, control system will clean or discharge the humidifier.

2. Controller

This touch screen adopts high-performance processor and window-operation system. The running state of the system is described by text, diagram or curve. All kinds of running parameters can be flexibly set by the unit to optimum state and make the man-machine conversion come true.

2.1 Homepage

In any circumstances, the screen will switch to the homepage as below once “**Home**” button is touched on the screen.



“**Home**” is working as the main control interface, which displays the current ambient temp. and humidity, ON/OFF, malfunctions, long distance monitoring, quick testing, faults, and shield touch screen etc.

There is a **Function Menu** on the right of the screen, which is displayed all the time. It consists of a group of touch buttons to realize the quick access to and control on the air conditioning system.

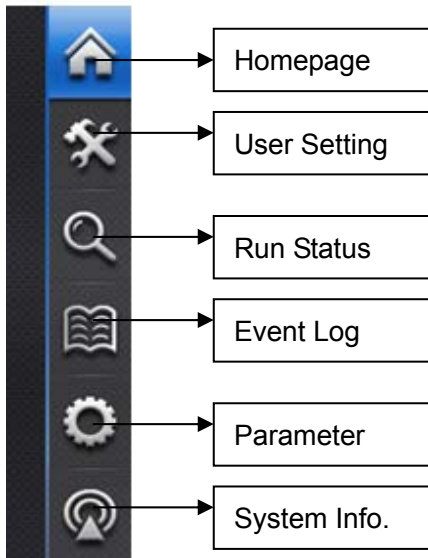

Function of each button is as follows:

“Home”: It is touched to enter the Homepage

“User Setting”: It can be touched to enter the interface for the setting of system temperature and humidity, status of each module, clock and timer.

“Run Status”: It is touched to enter the interface of running status which displays the running parameter of each module, status of each operating organization as well as temperature and humidity curve.

“Event Log”: It is touched to enter the interface of event log which provides the information of current error, current event and historical events.

“Parameter”: It is touched to enter the interface of parameter setting which requires codes to enter its 4 sub-function interfaces, including system parameter setting, sub module setting, service time and manual debugging.

“System Info.”: It is touched to enter the interface of system info., including system info. inquiry, maintenance notice and password reset.

Button-shaped area is touchable control area (text on the screen are the definition of functions), which can be touched by finger to execute specified command. The function of each touch button and the meaning of hint information are as follow:

“Return air Temp. & Humidity”: That is Average temperature and humidity detected by running modules which keep normal connecting with the main module. (If the entire modules are running, the average temperature is that of all running module units; if not, the average temperature is that of all independent running module units.)

On initial energization, temperature and humidity of each module disconnected communication links are display as 0.

“ON/OFF”: As it is touched, the system will issue a command to change the ON/OFF state. The hint information on the button will accordingly change to the current controlled running state of entire module. If the **“ON/OFF”** button shows that the current state is OFF and it is touched afterwards, the hint information on the button will change to “ON” meanwhile the start-up command will be issued by the system which is valid to the entire unit combined with modules. If needed to start each module unit, ON/OFF should be set in **“User Setting→module setting”**.

“Remote Monitoring”: When main module, communication module and monitoring computer are connected with each other correctly and software for remote monitoring is executed, **“Remote Monitoring”** will emerge. When the software is closed or the communication paused, the **“Remote Monitoring”** will disappear.

“Error”: It means there is malfunction. Related error information can be consulted on **“Event Log”→“Current Error”**

“Shield Touch Screen”: It means the touch screen has been shielded and all parameters cannot be set up unless by the “shielding/cancel shielding” operation of remote monitoring.

“Quick Test”: It means the touch screen enters into a quick testing status. This is only used for tests in the factory.

The above-mentioned “Remote Monitoring”, “Error”, “Shield Touch Screen” and “Quick Test” are not command buttons, but indications of events that occur to the touch screen.

Note: Touch screen takes 1 minute to save the set data, which means the set data or change of command will be saved to FLASH inside the touch screen after 1 minute. If power is off right after the setting, then the set data won't be saved because there is not enough time for saving, in which case, touch screen will still operate and display according to the previous parameters when it is re-energized.

2.2 User Setting Interface

(1) Humid&Temp. Setting Interface

This interface provides the customer with the setting for the unit temp., the unit humidity and their precision. The setting parameters are effective to the entire unit with combined modules.

Prevent conflicts between temp.&humid setting and upper/lower limits of temp.&humid:

Max value of return air temperature setting=upper limit setting of return air temperature(alarm) - 2°C, minimum value of return air temperature setting=lower limit setting of return air temperature(alarm) + 2°C,

Max value of return air humidity setting=upper limit setting of return air humidity - 3℃,
 minimum value of return air humidity setting=lower limit setting of return air humidity+ 3℃,

Minimum value of upper limit setting of return air temperature(alarm) >=integer of return air temperature setting + 2℃,

Maximum value of lower limit setting of return air humidity(alarm)=integer of return air temperature setting - 2℃.

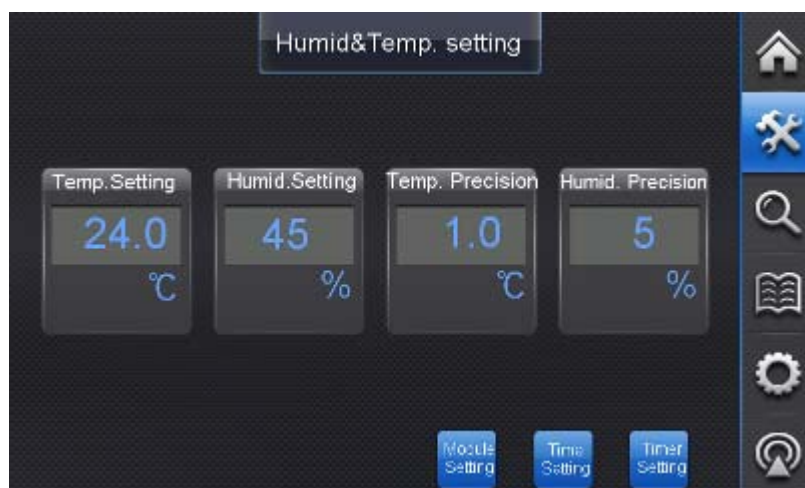

“**Module Mode Setting**”、“**Time Setting**”、“**Timer Setting.**”: Slightly press these buttons to enter the corresponding setting page.

“**Numeric Value Input**”: The numeric value with box represents what can be revised. By touching the number in the box, the keyboard interface is popped up and the number in the touched box displays the blinking cursor which means the number in the input state.



Touch the number in the keyboard. Input the revised number, and finally touch the “ENT” button in the keyboard to confirm the input. The keyboard will disappear subsequently, which means the finishing of the input.

Introduction to the buttons on keyboard:

“**Number Key**”: Number 0~9.

“.”: Decimal point, which for its input.

“**ES**”: By touching to cancel the input and the keyboard will disappear.

“**CR**”: By touching to erase the number inputted previously to input afresh.

“**ENT**”: By touching to confirm the input and the keyboard will disappear which means finishing of the input.

There are “max” value and “min” value on the top of the keyboard that are corresponding to the input range in the numeric box. If the numeric value exceeded the range is inputted, this input is invalid.

When the touch screen is shielded, “**Shield Touch Screen! Invalid Setting!**” will be shown on the right side of the interface. In that case, each setting interface is read-only and its parameter setting cannot be revised.

(2) Module Mode Setting

Slightly press the button “Module Setting” to enter the interface of “Module Mode Setting”

Only when unit is set off on the homepage can the mode setting of each module be effective on this interface.



“**Link/Break**”: When the connection is set, the module is connecting with and controlled by the main module; When the disconnection is set, the communication breaks and the module is out of control. At that time, related units are auto turned off which will be turned on by setting connection and the data of the unit on the touch screen shows 0.

“**ON/OFF**”: It means the unit of the module in the ON/OFF state.

“**Entire/ Alone**”: When the entire running is set, the module will be running together with the other entire modules, including alternate running, standby running; When the Alone running is set, the module will be running alone. Temp. and humidity is Subject to the unit itself without functions of alternation and standby.

“Auto/Manual”: When “manual” is displayed, the module is in the manual operation state. By touching it, the state will switch to auto running. But the reverse setting should be set in the **“Parameter Setting → Manual Debugging.”** In addition, if “entire” is set, manual mode is shielded.(Default to auto)

“Duty Time”: It means the alternately continuous running time of the entire running state of modules and the setting time range is 1~720 hours. Default time range is 96 hours. When the accumulated running time of the module has been reached the preset time for alternate running, the module will stop and the other standby module will start in order to make each module run in turn.

“Standby Units”: It means the standby units of modules stopped. Only the modules which are set to states of Link, ON, Entire running would be set to standby. When the Qty is 0, there are no functions of alternation and standby; when the standby units are bigger or equal to the Qty of entire running module units, all units that are qualified to be standby units will stop to be standby and there is no alternative running unit.

(3) Time & Date Setting Interface

Slightly press the button “Time Setting” to enter the interface of “Time & Date Setting”.



It can be revised by touching the corresponding numeric box.

(4) Timer ON/OFF Setting

Slightly press the button “Timer Setting” to enter the interface of “Timer On/Off Setting”. This function won’t be effective if module is in entire control or manual state, but will be valid when module is in independent auto mode.



2.4 Running Status Interface

(1) Output Status View

This interface displays the running information of each module (e.g. Connected /Disconnected, On/Off, Entire control/ Independent operation, Auto operation / Manual operation, Normal / Error, Emergency).

“Emergency” will not arise in normal running status unless the unit is in emergency running status.

Slightly press the button “Run Data” to enter the interface of “Data Inquiry”. Slightly press the button “Run Curve” to enter the interface of “Running Curve Inquiry”. Slightly press the button “History Curve” to enter the interface of “History Curve Inquiry”.

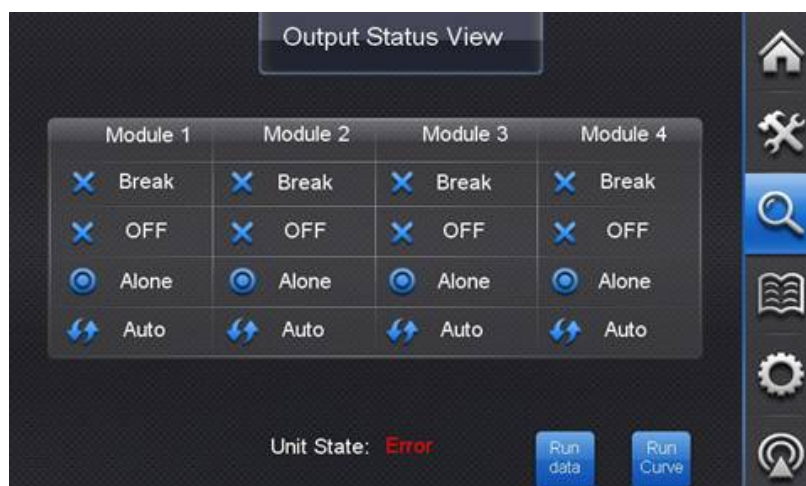

(2) Data Inquiry

The current inquired module, including the on/off status and parameters of each part, is displayed. Press the button of “Switch Module” to switch the data from module 1 to module 4.

On this page, running status and parameters of each key part can be viewed, including the

on/off status of indoor fan, compressor 1 and compressor 2, and the pulse of electronic expansion valve. On the interface of “Output Status View”, press “**State**” and then enter the interface of running data inquiry, the pulse of electronic expansion valve is displayed. After entering the homepage, the pulse of EXV will not be displayed.

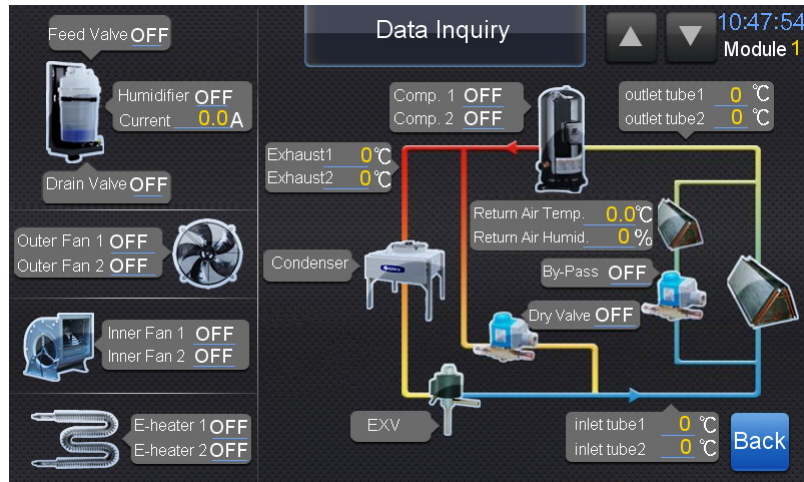

If error exists in the unit, then “Error” will be displayed.

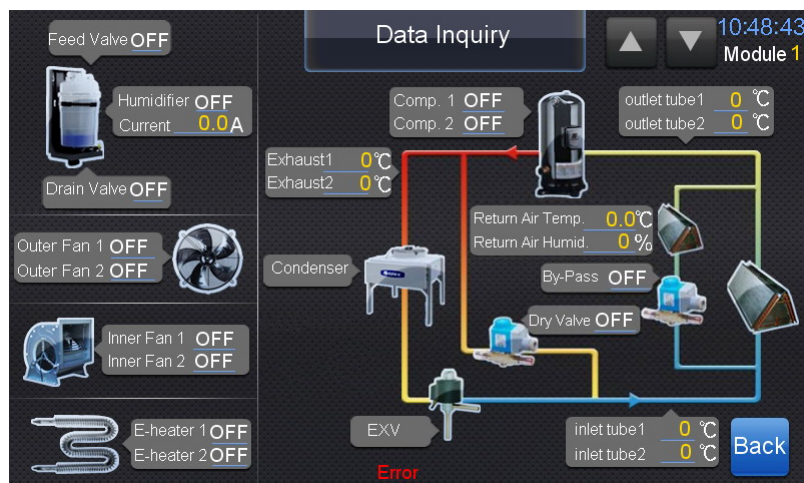

If the module is set as break status, all the corresponding search data is 0.

(3) Running Curve Inquiry

The interface of running curve inquiry displays temperature curve and humidity curve. The horizontal abscissa represents time whereas the vertical ordinate represents temperature or humidity. Red line indicates the return air temperature and the pink line indicates the return air humidity, with the current temperature or humidity value showing at the bottom of the curve diagram. Slightly press module 1, module 2, module 3 or module 4 on top of the curve to switch to the corresponding module.

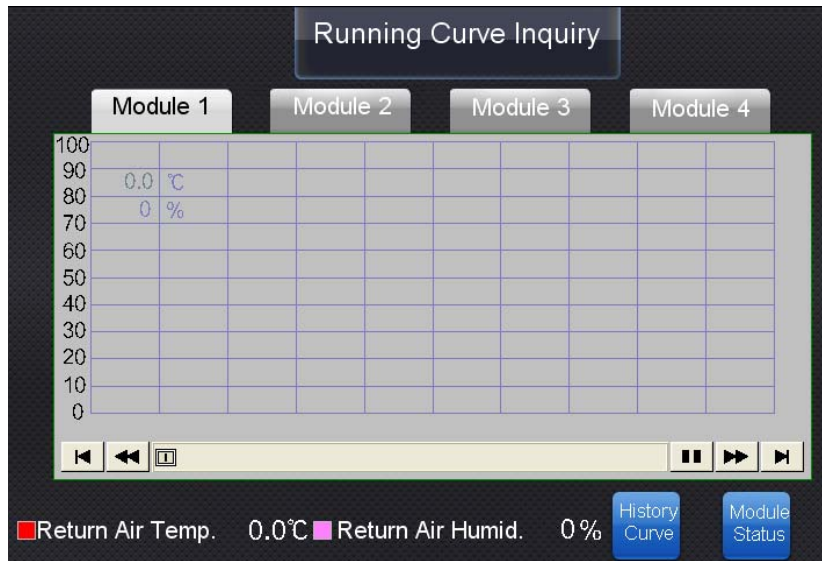

(3) History Curve Inquiry

The interface of running curve inquiry displays temperature curve and humidity curve. The horizontal abscissa represents time whereas the vertical ordinate represents temperature or humidity. Red line indicates the return air temperature and the pink line indicates the return air humidity, with the current temperature or humidity value showing at the bottom of the curve diagram. Slightly press module 1, module 2, module 3 or module 4 on top of the curve to switch to the corresponding module.

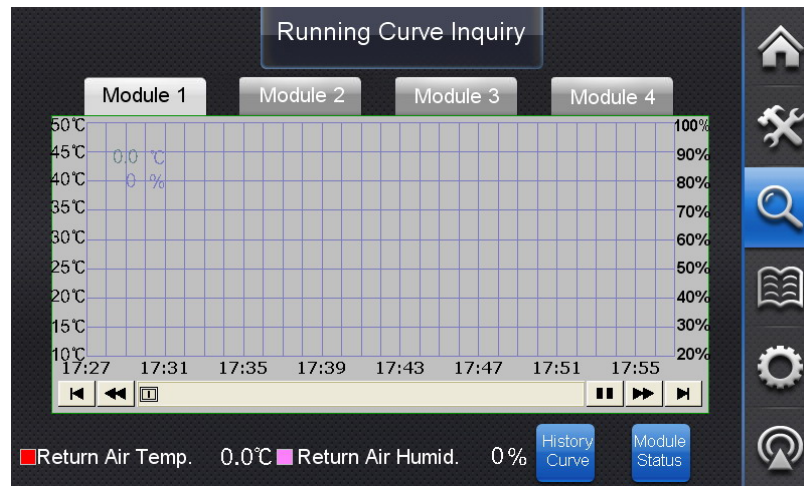

(4) History Curve Inquiry

The button “**History Curve**” is only displayed on the interface of running curve inquiry. The running curve before unit in last power-off can be viewed. Slightly press module 1, module 2, module 3 or module 4 on top of the curve to switch to the corresponding module.

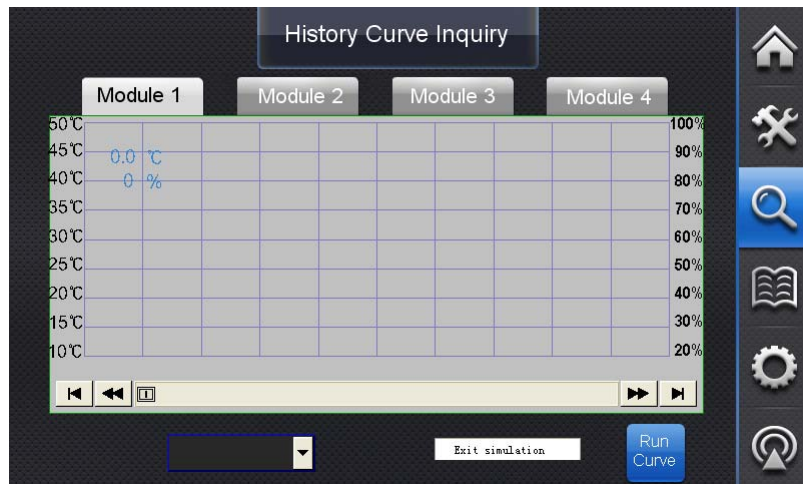

History curve of a certain day can be viewed by selecting the date.

2.5 Event Log

(1) Current Error

Slightly press “**Event Log**” and then the interface of current error will be displayed. This interface shows the current alarms of the unit, which can be viewed one by one by touching the right and lower scroll bars.

Press and hold the button “**Reset**” for 5 seconds, then all the current errors will be reset.

When screen is locked automatically, the button “Reset” is ineffective.

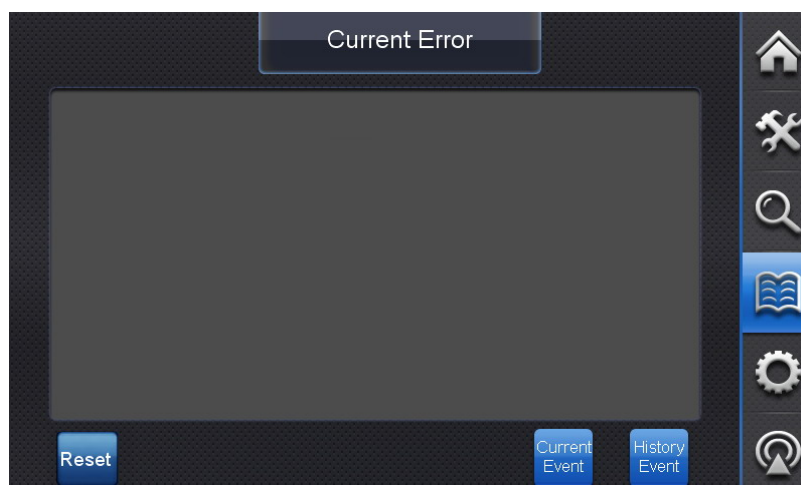

(2) Current Event

Slightly press the button “Current Event” to enter the interface of current event. Then all events happened since unit is turned on this time will be shown. Events can be viewed one by one by slightly touching the left and right scroll bars. System can record 100 current events at most. Red indicates the event is happening. Press the event of error to confirm and the color

will change to yellow. When error is recovered, the color will change to green.



(3) History Event

Slightly press the button “History Event” to enter the interface of history event. This interface displays the record of events that occur before the unit is last turned off. You can choose the start date of events. Blue indicates that events are happening while green indicates that events are recovered and yellow indicates that events are confirmed.

Note: “?” will appear when all “History Event” records are cleared.



2.6 Parameter Setting

Slightly press the button “Parameter Setting” and a window will pop up requiring password input. The access to the interface of parameter setting needs a password. Click the password input box and input: “111111”. Wrong password denies access. Password will be effective until the touch screen is back to homepage. After inputting the correct password, slightly touch the

button “Close” and then touch the button “Parameter Setting” to view or operate the interface of “System Parameter Setting”, “Sub-Module Setting”, “Module Service Time”or “Manual Debugging”



(1) System Parameter Setting

Slightly press the button “Parameter Setting” to set parameters for the system of master module. Slightly touch the value input box to modify the values.

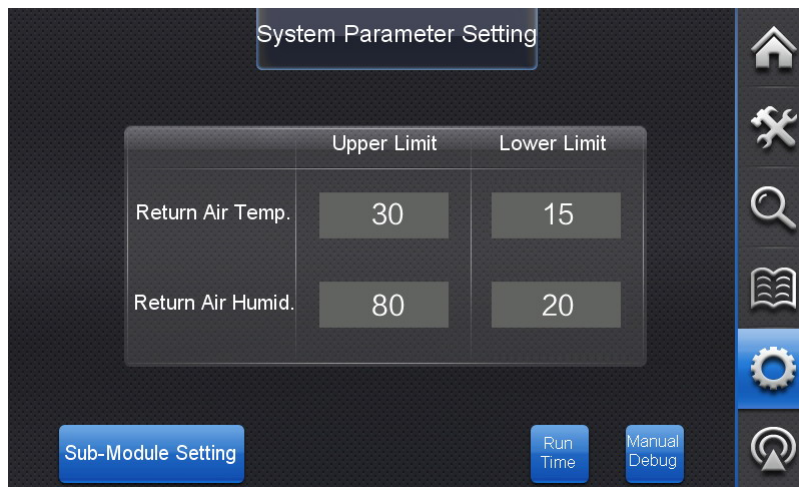

(2) Sub-Module Setting

Slightly press the button “Sub-Module Setting” to adjust parameters for each sub-module, restore default setting or set function shield. Slightly touch “Back” to return to the previous page. Press module 1, module 2, module 3 or module 4 to switch to the corresponding module.

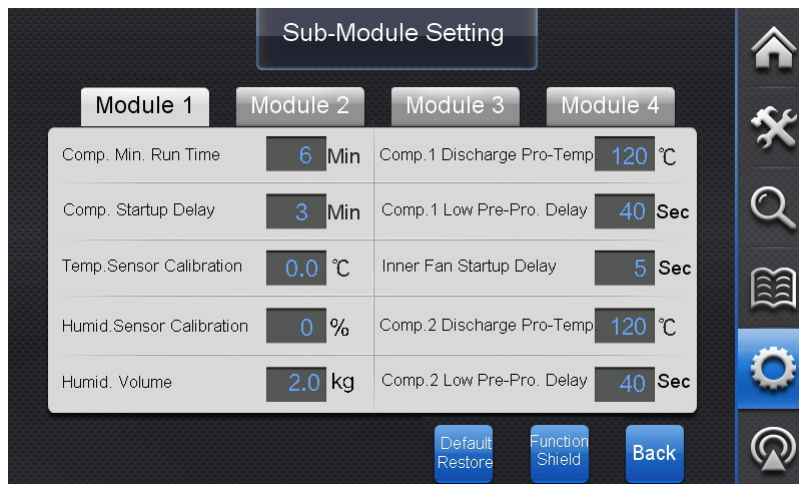

The return air temperature and humidity sensor has been tested before the unit is delivered out of the factory. If any deviation is found during application, it can be corrected according to the following method. Suppose that the temperature and humidity detected by the unit is X°C

/Y%, if the corrected value of temperature probe is set to be x°C, the temperature tested by the unit is X+x°C; if the corrected value of humidity probe is set to be y%, the humidity tested by the unit is Y+y%. For example, if the ambient temperature and humidity is 23°C/55%, and the temperature and humidity tested by the unit is 23.2°C/52%, the corrected value of temperature probe shall be -0.2°C and the corrected value of humidity probe shall be 3%

Slightly press the button “Default Restore” and a window will pop up. Press “Enter” to restore ex-factory setting or press “ESC” to cancel the request.

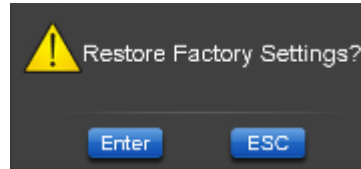

Slightly press the button “Function Shield” to activate shield function against heating, energy saving, humidifying or antistatic. Once the setting is changed, it is enabled. On the pop-up page, slightly press the character “Shield” of “Function Shield” on the top left corner, then the capacity switch code value of each module will be displayed.



(3) Module Service Time

Slightly press the button “Run Time” to view the accumulated service time of each module and its subsidiary parts. Slightly touch the button “Reset” to clear the service time of the corresponding module or its parts. Note: Clearing the accumulated service time will affect module’s operation!

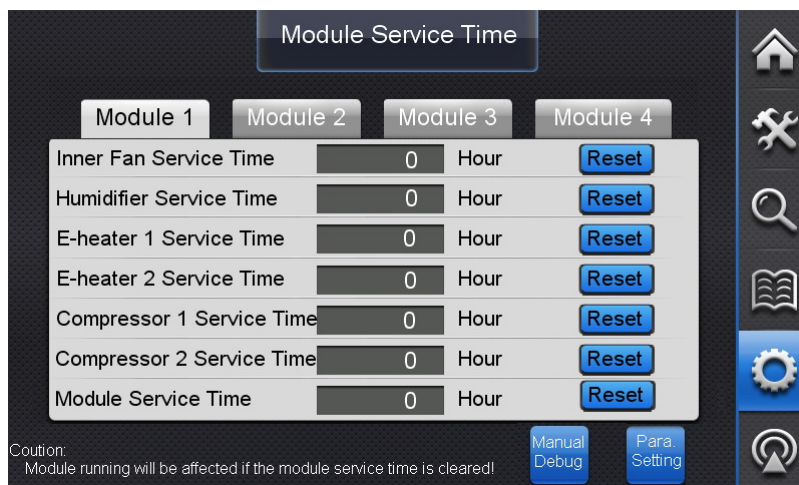

(4) Manual Debugging

Slightly press the button “Manual Debug” to turn on or off the parts of each module.



Slightly touch the button “ON/OFF” on the right side of the running part to switch to the manual on/off status of the corresponding part. Words on the button indicate the manual on/off status of the corresponding part.

Under independent auto mode, slightly touch the button “Enter Manual Mode” to enter the manual operation mode. Then each part of the system will run according to the on/off order set for each part. This button will then show words of exit manual mode. Meanwhile, on the interface of “Running Status”, button “Manual/Auto” of the corresponding mode will display “Manua”l. See “4. Running Status Interface” for more details.

Slightly press the button “Exit Manual Mode” to exit the manual operation. Then unit will switch to auto mode and the on/off order set for each part will be invalid.

Note: If units work as a whole, manual debugging is not available.

2.7 System Information

(1) System Information

Slightly press the button “System Info” to view “Maintenance Notice”, adjust screen setting, change password or restart the touch screen.



Language of the touch screen can be selected on this page.

Slightly touch the backlight time input box to determine the backlight time of the touch screen.

Slightly press "ON" or "OFF" button to turn on or off the keypad tone.

Touch the button "Restart" slightly for at least 3 seconds, then the touch screen will be restarted. In order to ensure system's stable operation, please restart the touch screen when units are turned off. When touch screen is shielded, this button is ineffective.

Note: Restarting the touch screen will clear the temperature and humidity curves.

When screen is locked, you cannot change password, switch between Chinese and English, set backlight or keypad tone, but you can set when PC shield. After screen is locked, slightly press "Unlock" and enter a correct password "111111". Then slightly press "Unlock" again to unlock the screen.

(2) Change Password

Slightly press the button "Modify PWD" to reset user's password.



Press “Enter” and if password is valid, it is modified successfully. If not, input password again.

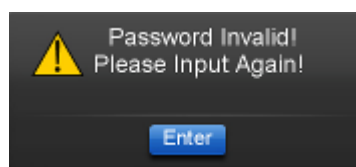
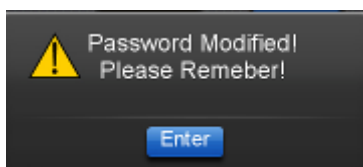

(3) Maintenance Notice

Slightly touch the button “Maintenance Notice” to switch to the page of maintenance notice. User can view information related to maintenance and installation.

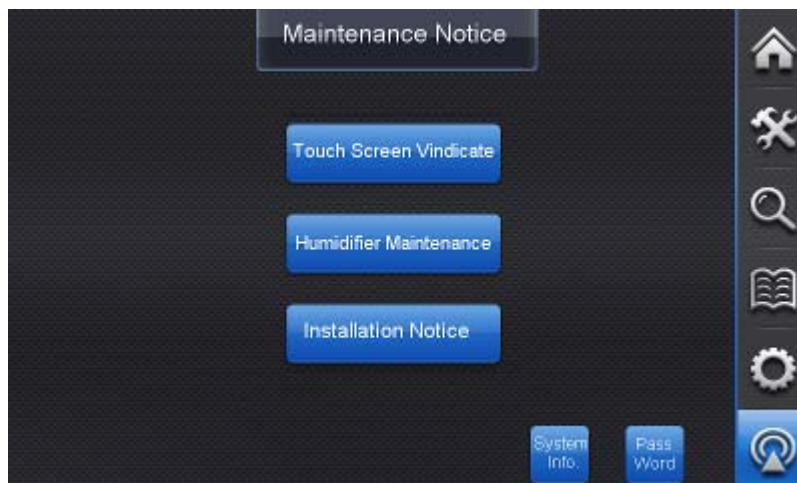

Slightly touch the button “**Password**” and the password input interface will pop up. Input password “333333” and slightly touch the button “**Password**”, the password will pop up.

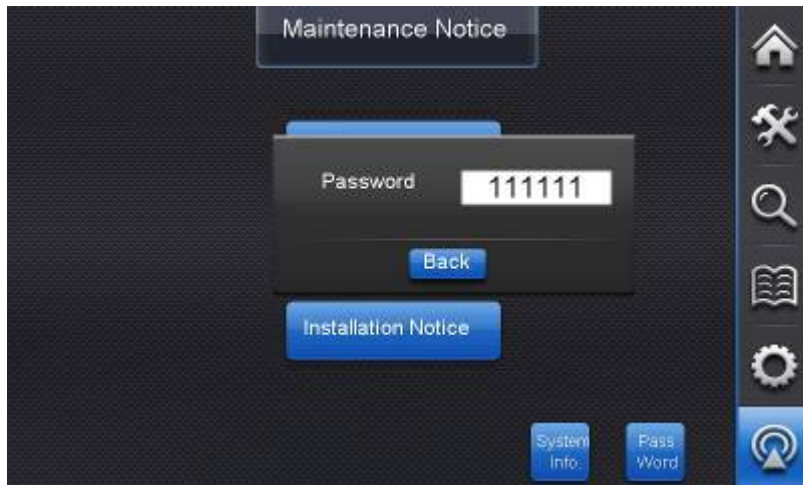
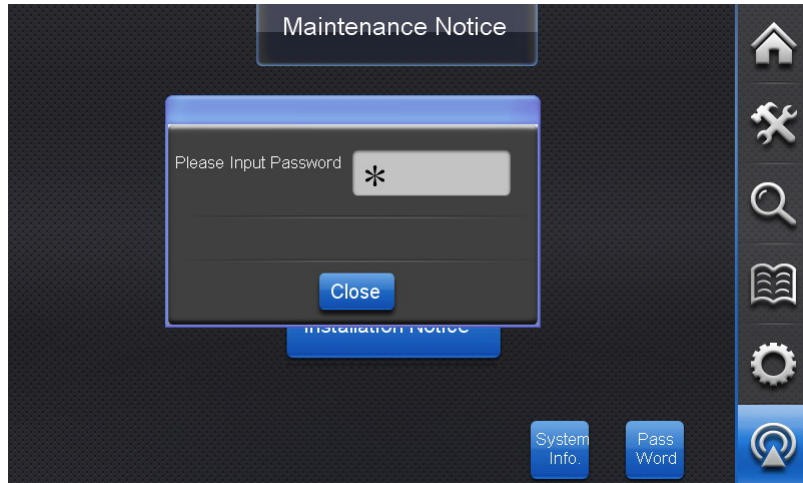

Slightly touch the button “**System Info.**” And the password input interface will pop up. Input password “55555” and then you can clear event, clear curve and modify PWD.



Slightly touch the button “**Clear Event**” and click “Enter” on the pop-up box to clear all historical event records. Click “ESC” to return.

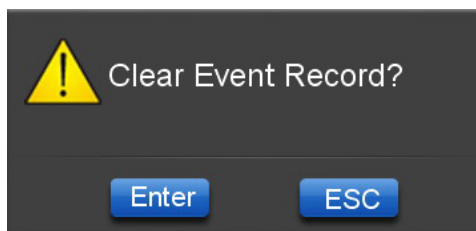

Slightly press the button “**Clear Curve**” and click “Enter” on the pop-up box to clear all historical curve records. Click “ESC” to return.

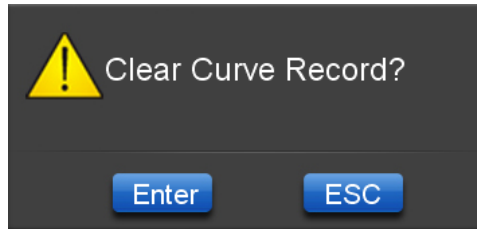

Slightly press the button “**Maintenance Notice**” and input password “330000” on the pop-up box of energy saving mode setting interface to set energy saving mode. Press “ESC” to close this window and return to “Maintenance Notice”.



2.8 Touch Screen Caring, Humidifier Maintenance and Installation Notice

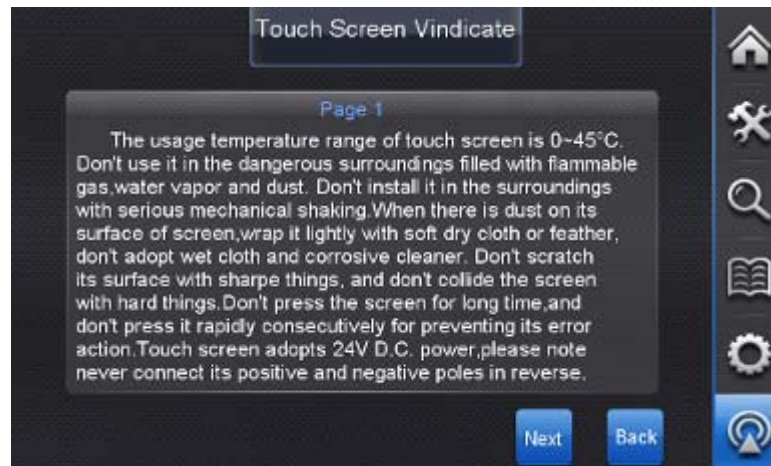

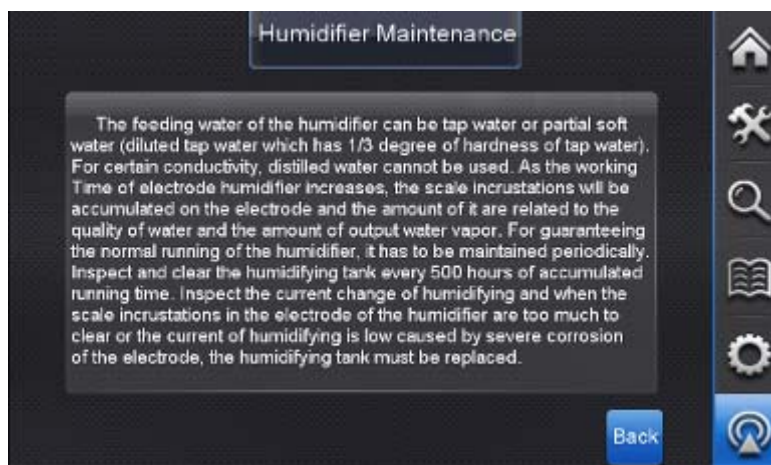
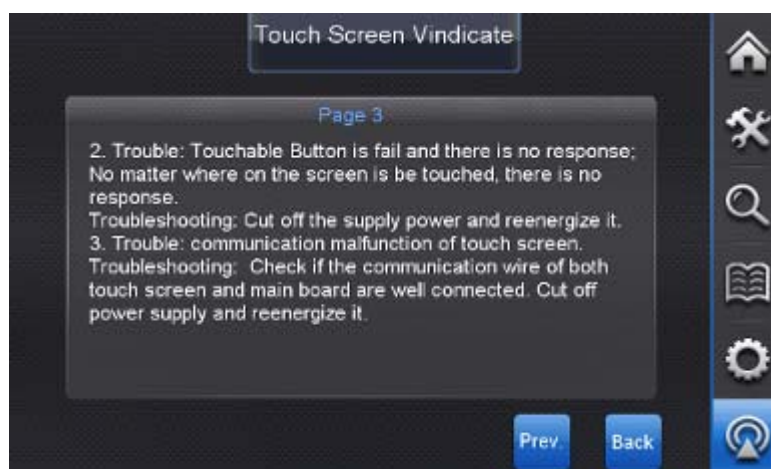
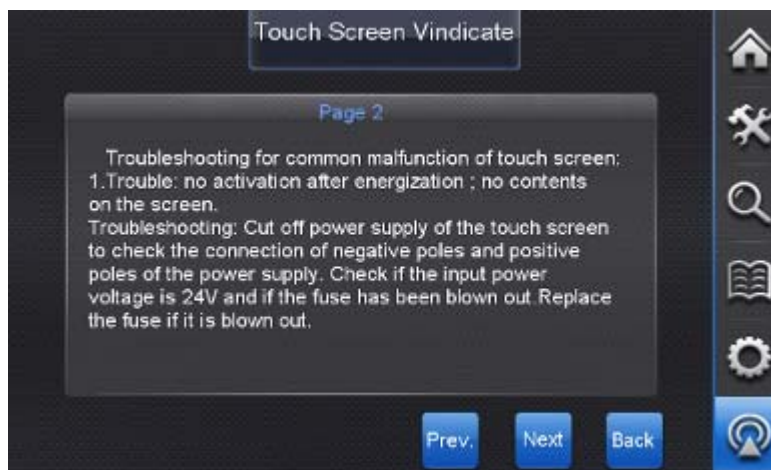



3. The Instruction of DIP Switch

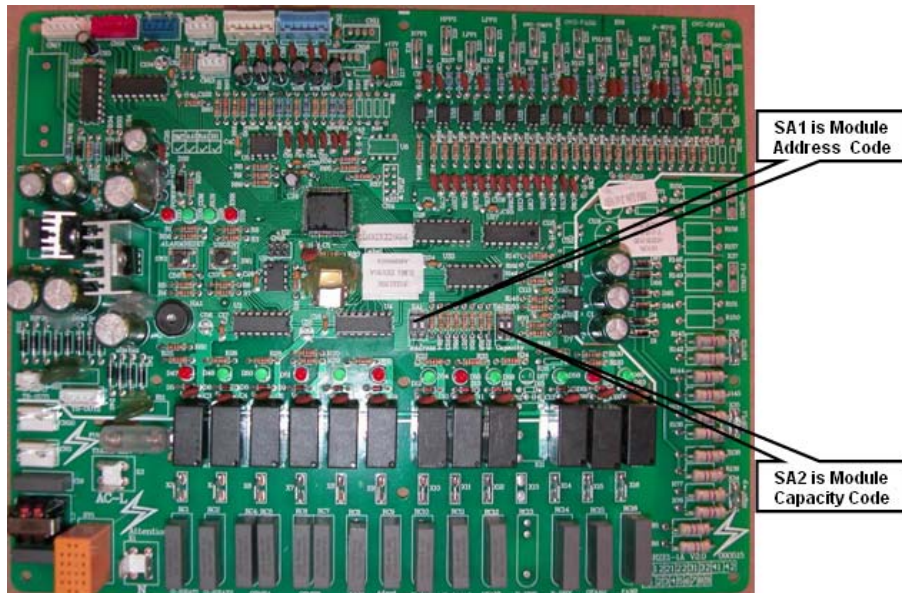

Units Mainboard DIP Switch Diagram

3.1 Address Code

Four modules can be combined to run integratedly by 2-bit setting address of DIP switch on SA1 in mainboard of each module. Code is valid before energization and its change is invalid after energization. Coding method is as follows:

SA1 Address DIP switch		Address Code
2	1	
0	0	1#
0	1	2#

1	0	3#
1	1	4#
The DIP switch at the position ON represents "0" and at digital terminal represents "1".		

3.2 Capacity Code

Capacity code of the unit is the 2-bit DIP switch on SA2 in the mainboard which has been set and fixed by the factory. Users and installation personnel cannot change it.

Note: Address code and Capacity code are valid before energization and the change is invalid after energization.

4. Remote Monitoring

Combined parameter characteristic of Air Conditioner and adopted MODBUS communication protocol, this software is designed to provide simple operation interface to view the running status of every unit in real time and set related parameter in long distance with monitoring PC.



Note: the remote monitoring accessories are not contained in the standard product; the user should select the accessories according to the requirement.

4.1 Installation

4.1.1 System requirements for Gree AC Eudemon 2009

- ※ Internet Requirements: Microsoft Internet Explorer 6.0 SP1 or later (prerequisite for .NET Framework)
- ※ RAM: Minimum: 1 GB. Recommended: 2 GB or higher.
- ※ Hard Disk space: 10 GB free space
- ※ Processor: Core 2 or higher Minimum: 1 GHz Recommended: 2 GHz or higher
- ※ Operating System : Windows Server 2003 SP2

Windows Server 2003 Enterprise Edition SP2

Windows XP Professional SP2

Windows Vista Business

Windows Vista Enterprise

Windows Vista Ultimate

Windows 7

4.1.2 Installation, operation and uninstall

- **Install**

If you are installing Gree AC Eudemon 2009, you must run Setup as an administrator, put the CD in CD-ROM, run the autorun.exe.



Perform the following steps in order:

1. Install Microsoft SQL Server 2005 Express Edition
2. Install Microsoft SQL Server 2005 SSMSEE
3. Install Vcredist_x86
4. Install Gree AC Eudemon 2009

Click “help” for installation flow.

• Run

Click “start→program→GREE→ Gree AC Eudemon 2009” or double-click  on desktop to start this software, the interface is as following:

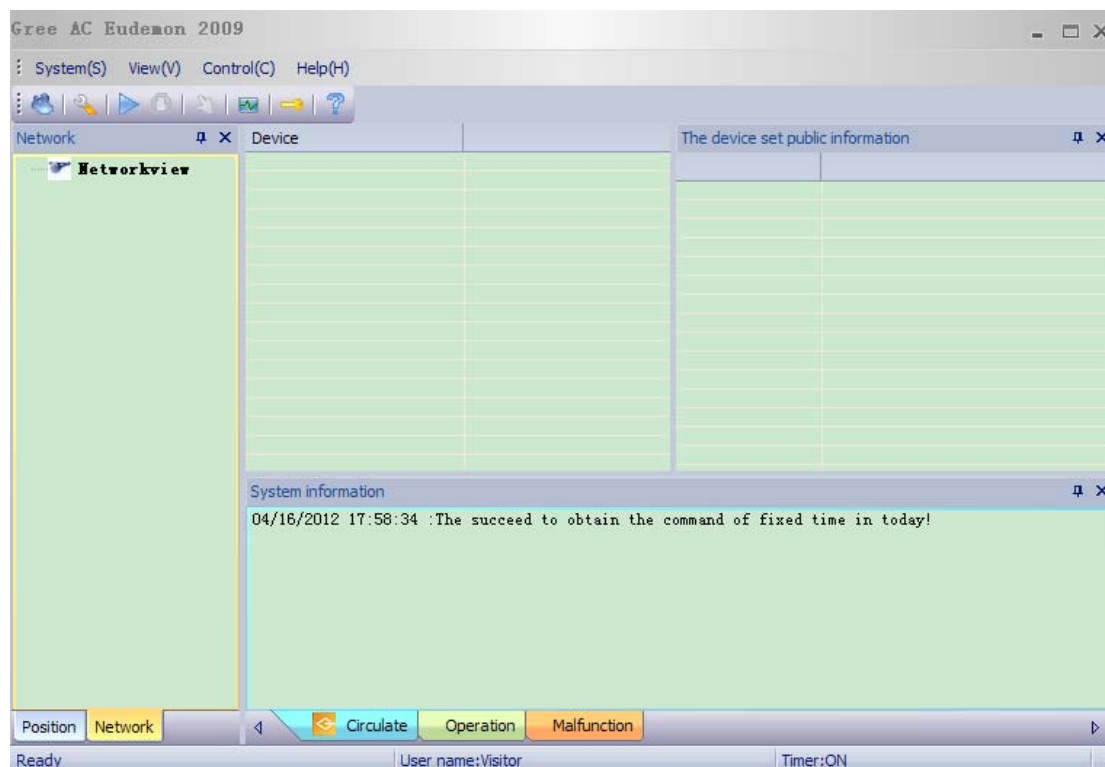

• Uninstall

Double-click the system icon in Control Panel to uninstall this program.

Click  from “start→program→GREE→Gree AC Eudemon 2009” to uninstall the

program.

4.2 Operation

4.2.1 Login Window

Run Gree AC Eudemon 2009.exe as an administrator in the installation catalogue. (The shortcut of "AC Eudemon 2009" can be found in Menu Bar or desktop)

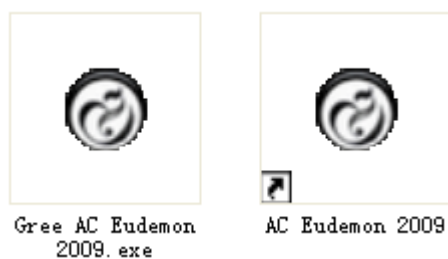

The pop-up interface of the software will be as below:

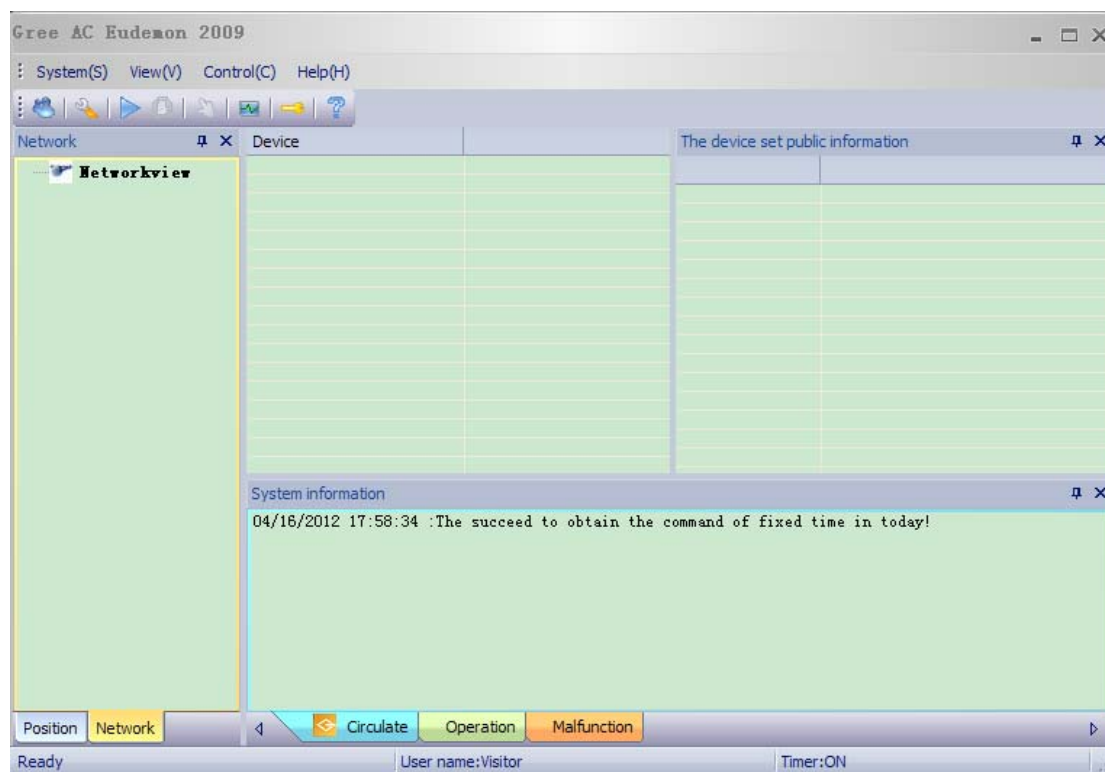

Click Main Menu->System ->The customer login. Then input user name(admin) and password(null) and click Login.

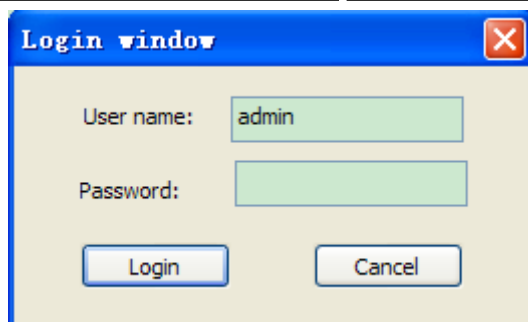

4.2.2 The Engineering Install

Click Main Menu->System->The engineering install, and then fill in the engineering information. Click "OK" to finish the configuration.

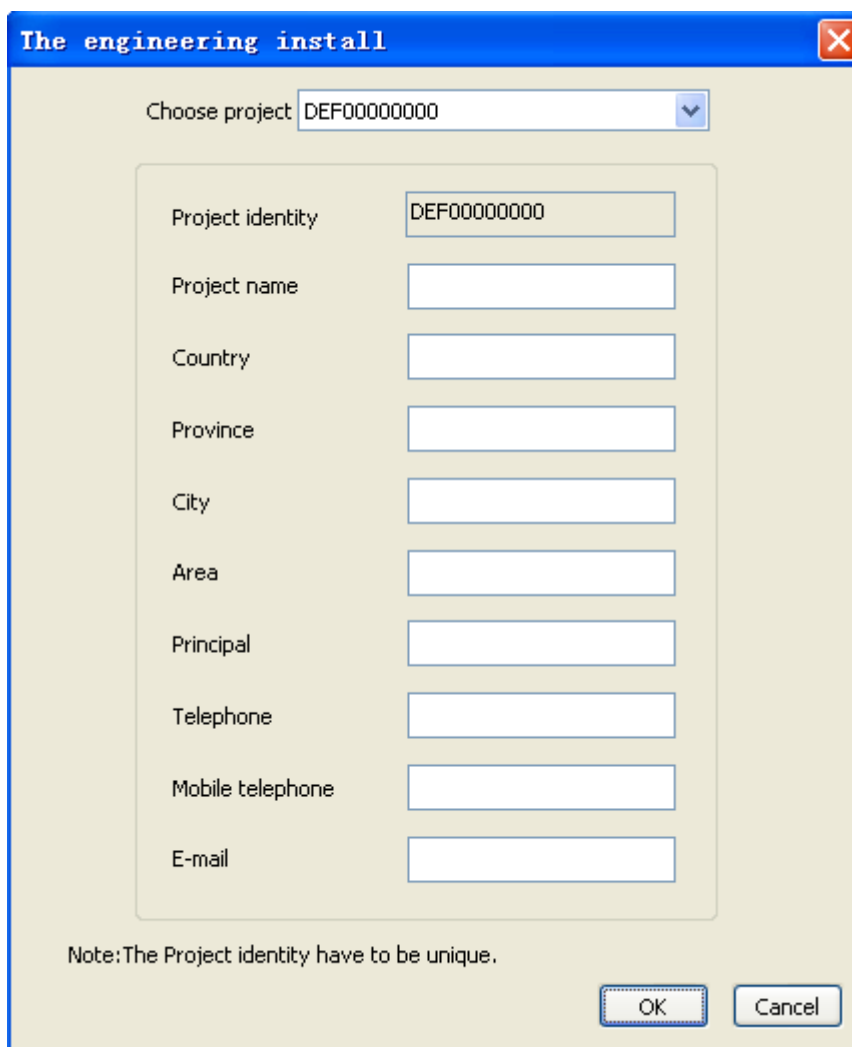

4.2.3 System Configuration

Click Main Menu->System->The system install and the following interface will show.

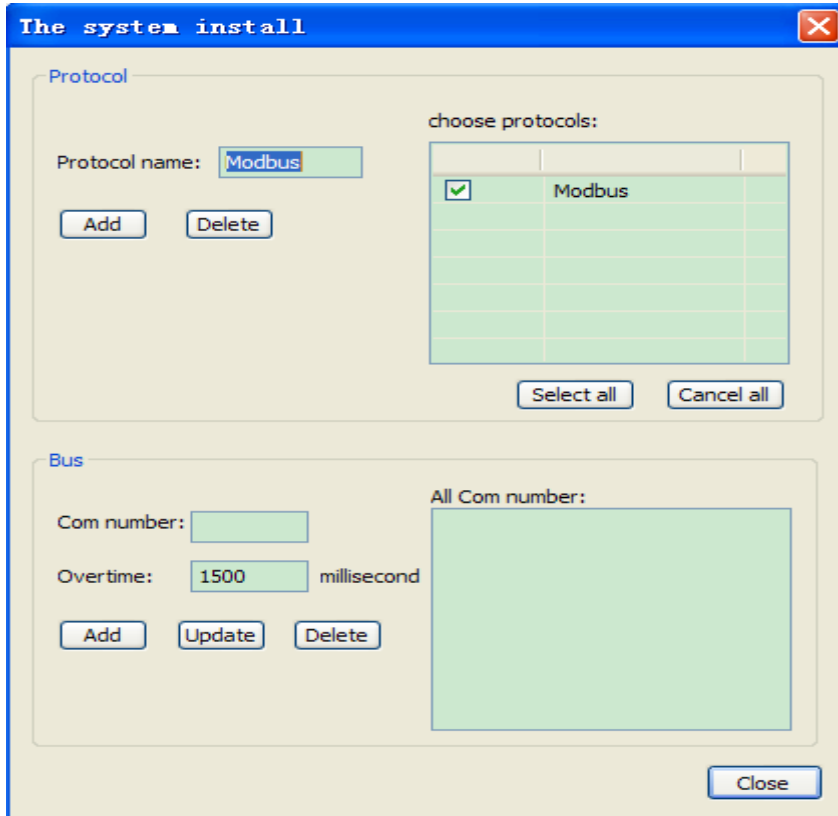

Set parameters as the following interface and click Add button. Overtime means after software sending a request command. Communication module should give a response in 1500ms . this value can be changed

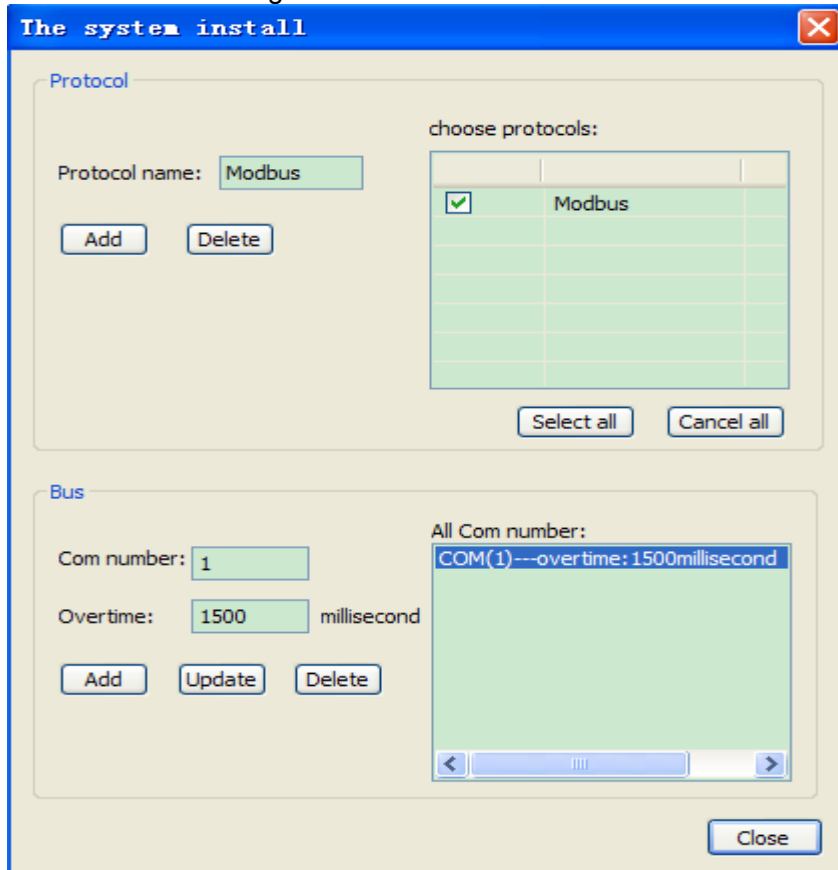

Now, the system supports Com1 and Modbus.

4.2.4 Bus Configuration

Click Main Menu->System->The bus install and the interface of bus configuration will show.

The screenshot shows a 'Bus configuration' dialog box. It has a title bar with 'Bus configuration' and a close button. The dialog is divided into two sections: 'All identity' and 'Add new'. The 'All identity' section contains a 'Choose identity' dropdown menu and an 'Address' text box with a 'Delete' button. The 'Add new' section contains a 'Bus identity' text box with 'Bus1' entered, a radio button for 'Com' (selected) with a dropdown menu showing '1', and a radio button for 'TCP/IP' with a text box containing three dots. At the bottom of the 'Add new' section are 'Add' and 'Update' buttons. A 'Close' button is located at the bottom right of the dialog.

Select the COM number in "COM". COM1 is used in this example. Then input "Bus1" in "Bus Identity", that is decided by yourself and click Add as the following figure. Click "Close" to finish adding the bus.

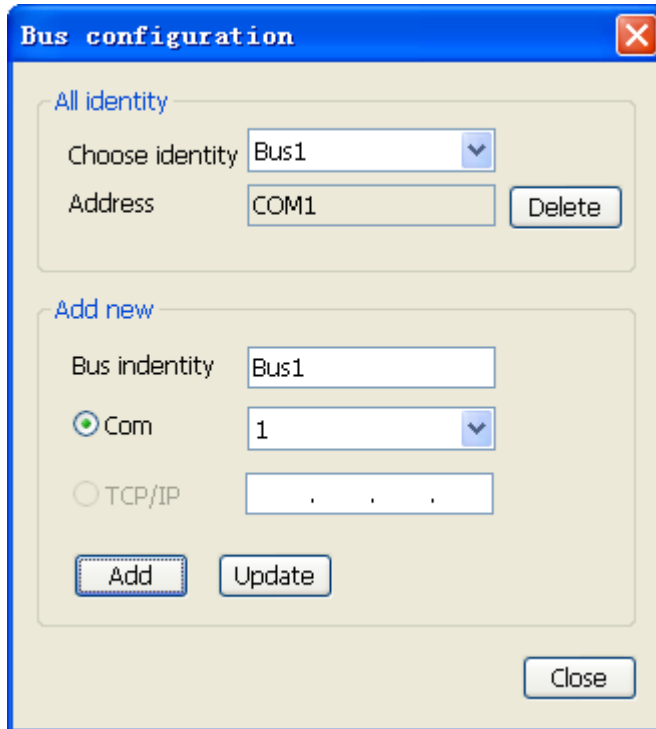

4.2.5 Automatic Examination

- Configuration of automatic examination: Click Main Menu->System->The equipments examines automatically.

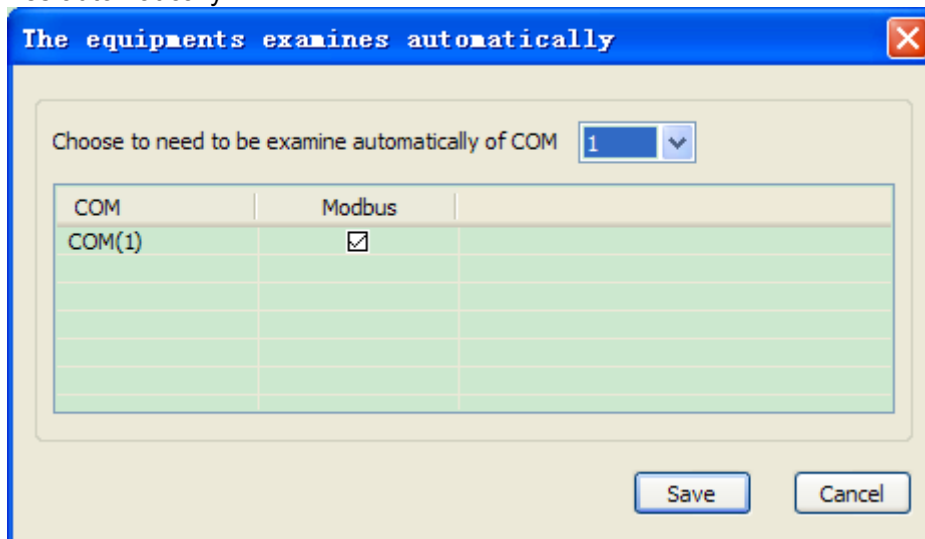

In this example, COM(1) and Modbus are selected as the above figure and then click Save.

- Automatic examination: click Main Menu->Control->Automatic Examination and the system will start automatic examination function.

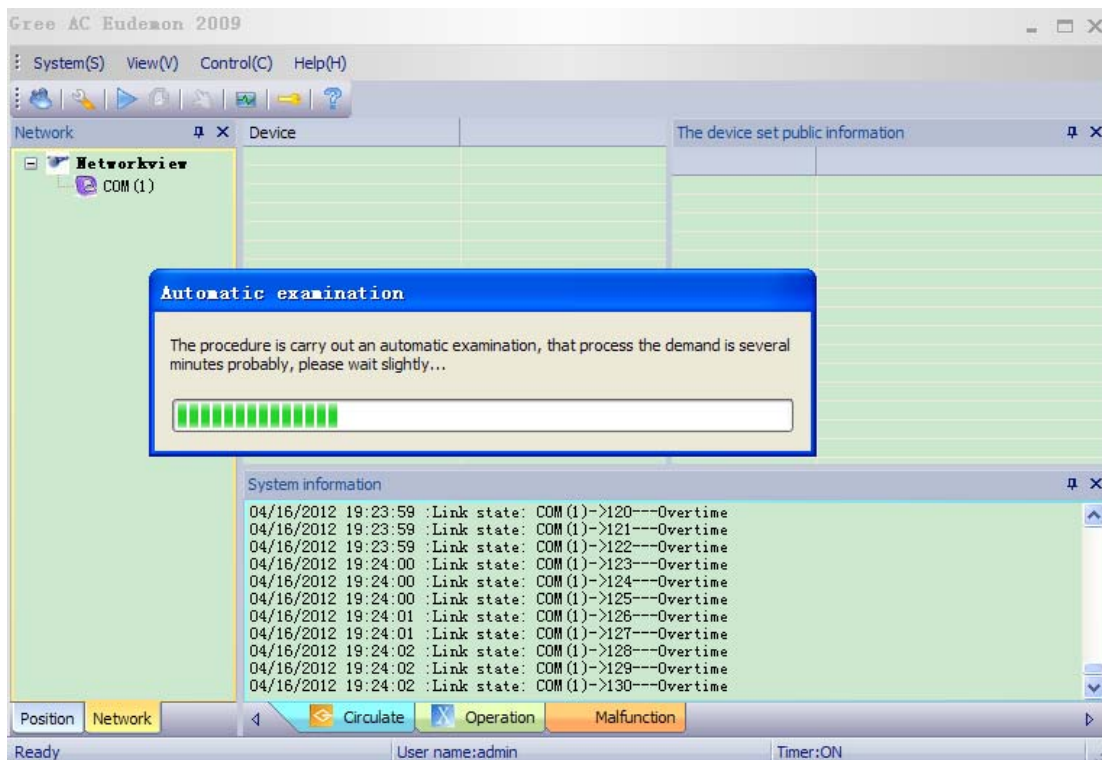

- The result of Automatic examination in the example is as below (pay attention to the networkview on the left):

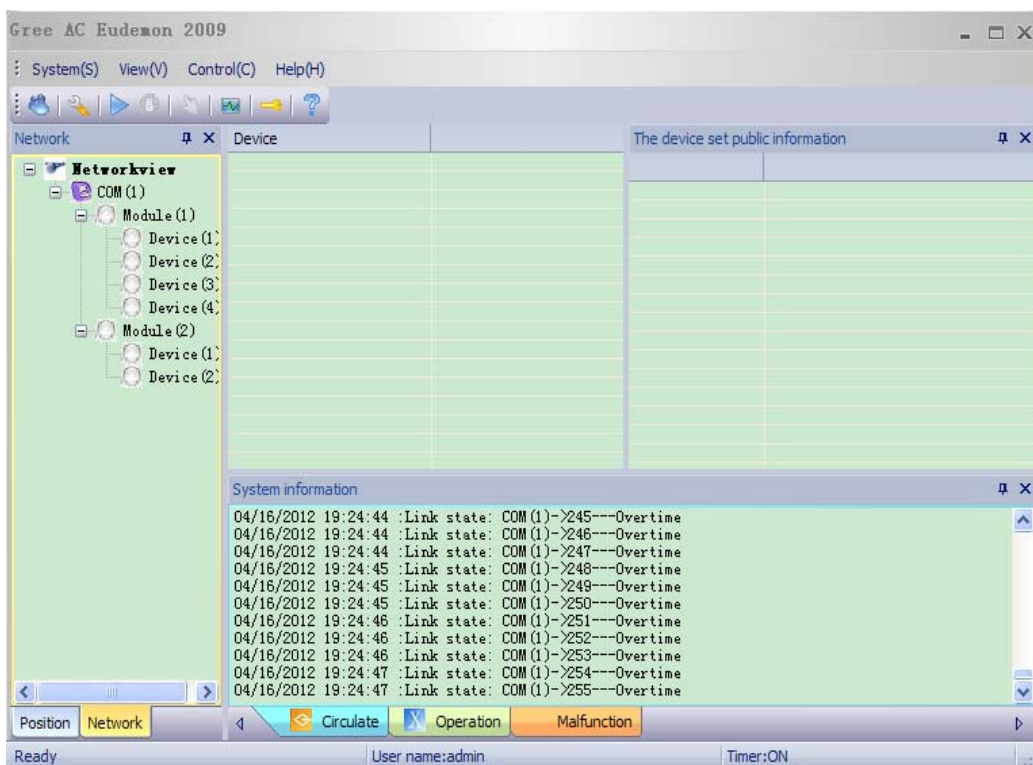

So far, the equipment is added successfully.

Note: Unit installation sketch is as following, please make sure the installation is complete and the communication is normal before running inspection Automatic examination.

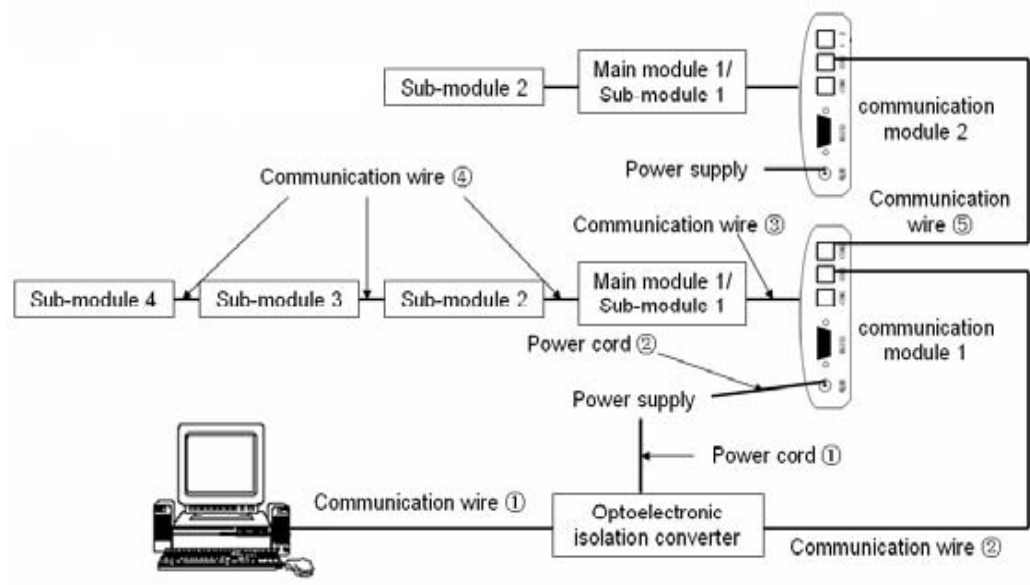

4.2.6 Equipment Management

Rename the equipment: left click Equipment to select "Rename".

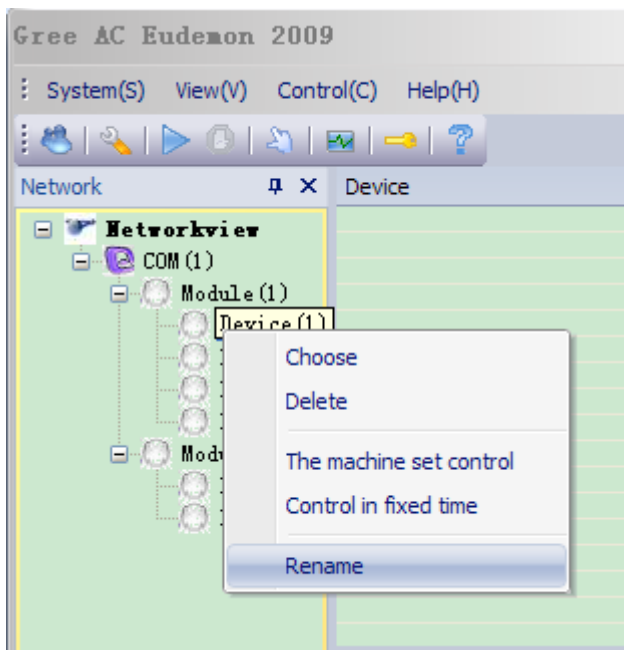

Fill in the name "Closed Control Air Conditioner ".(the name is decided by yourself)

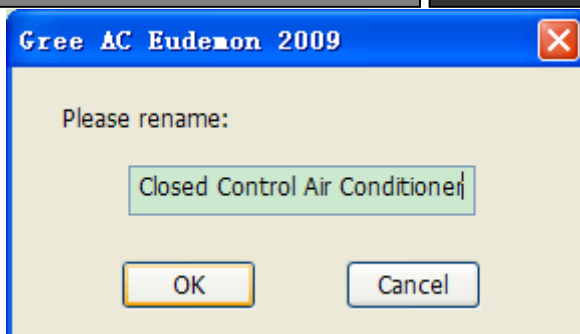

The result is as below:

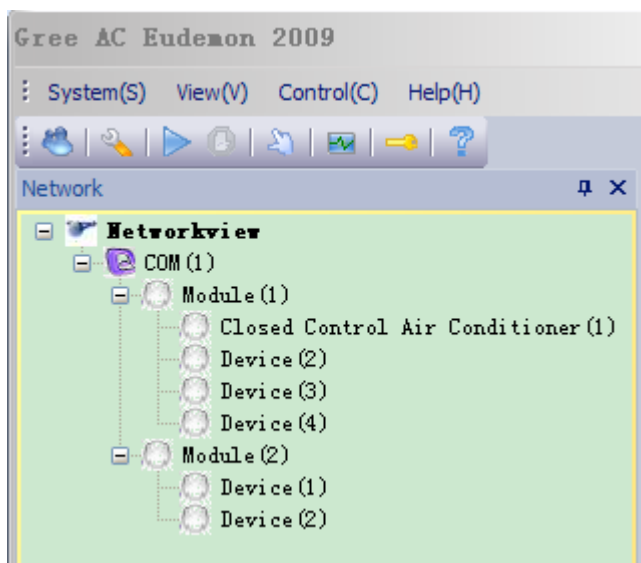

4.2.7 Connect Equipments

- Link management: Click Main Menu->System->Connect management (COM1 is applied in this example) and then click "OK".

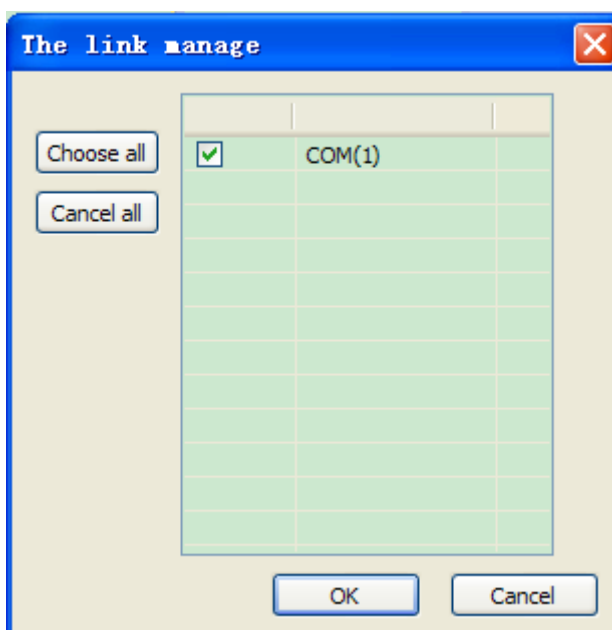

- Start Communicating: Click Main Menu->Control->Link an equipments and the system can communicate with the unit. In this case, you can check the data of units.

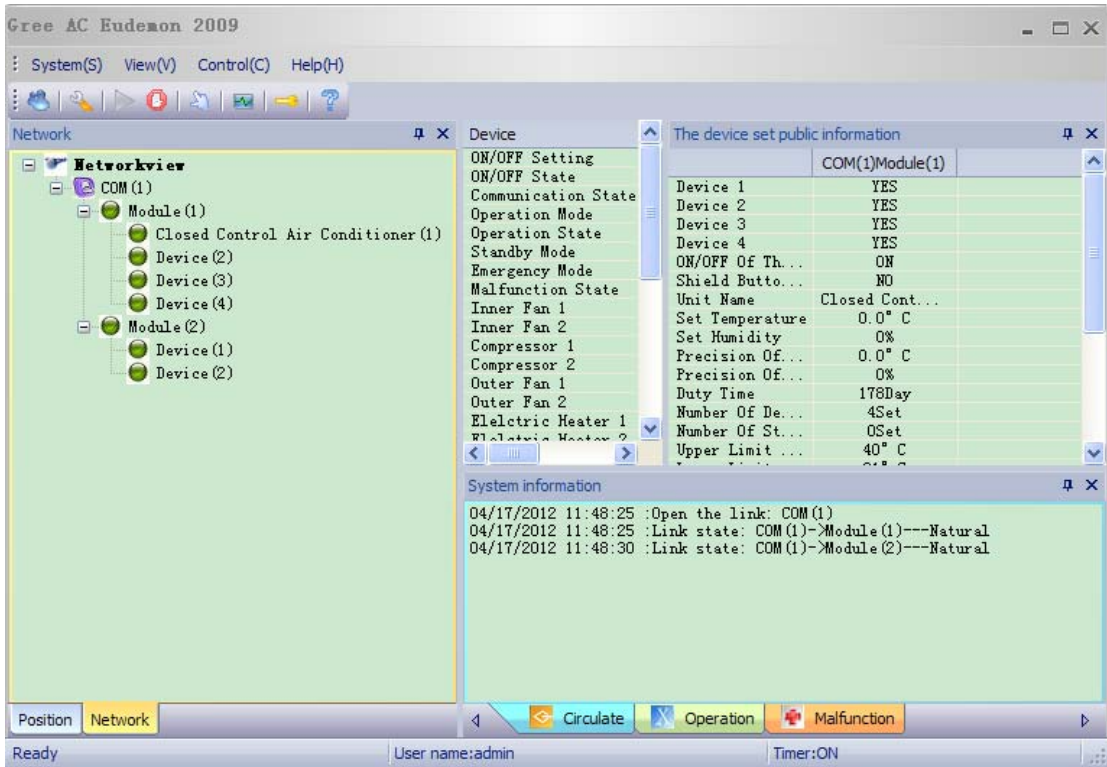

4.2.8 Control Unit

- Left click any Device in Module(1), select "The machine set control" in popup menu after right click, as following picture shows:

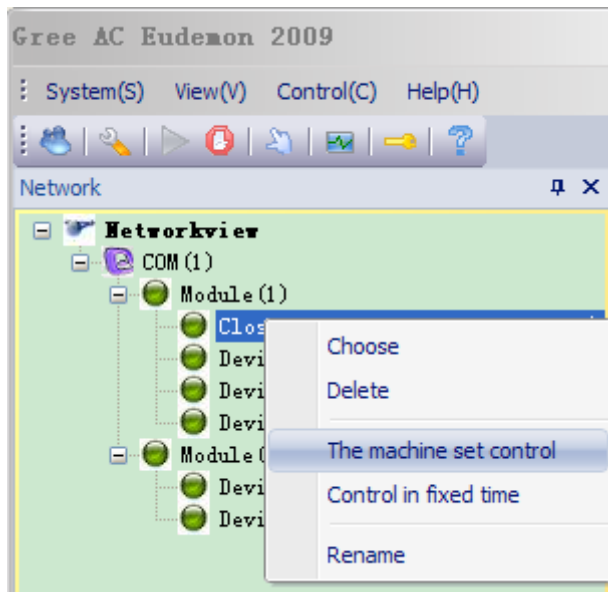

After setting the parameter in control interface, click "OK" to start operation as the figure below. No.1、No.2、No.3、No.4 in following red frame refer to Device(1)、Device(2)、Device(3)、

Device(4) in Module(1), when the check box before “No” is selected, the setting information in related blue frame will be sent to the unit after pressing “OK”, otherwise the settings in blue frame is invalid.

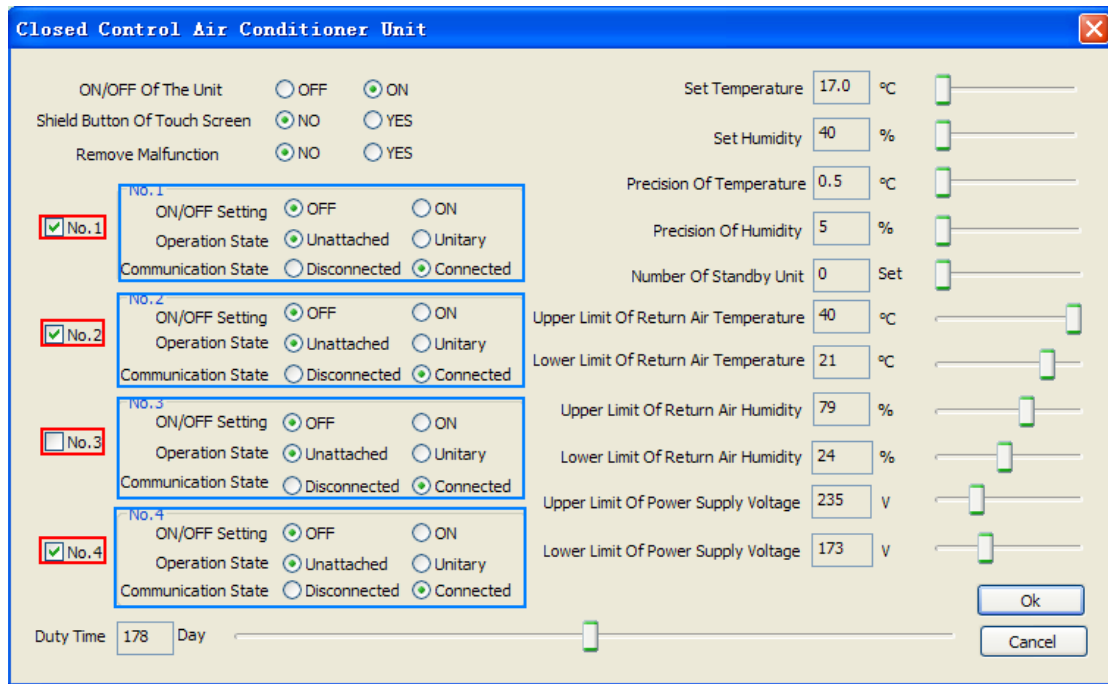

Check whether the modification is success or not by returning to the main interface.

- Left click any Device in Module(2), select "The machine set control" in popup menu after right click, as following picture shows:

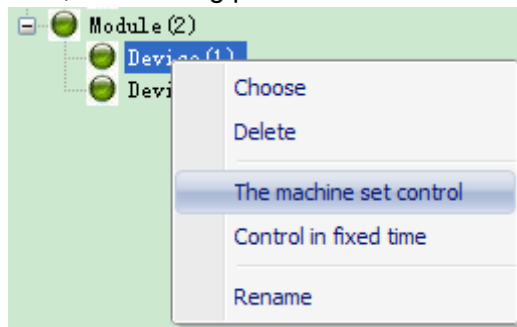

Popup control interface is as following, notice the red frame part, since there’s no Device (3) and Device(4) in Module(2), the related control part is not available for setting. Other operations are the same as 2.8.1.

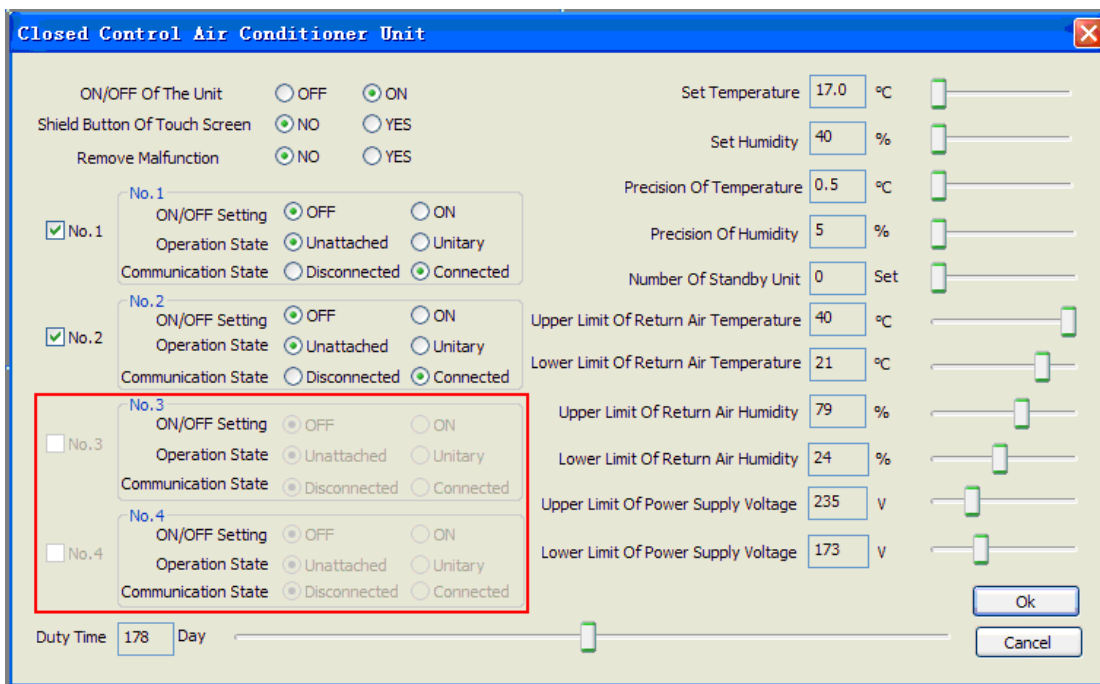

4.3 Display interface

Main interface consists of “menu”, “tool”, “network view”, “parameter view”, “system information view” and “status”.

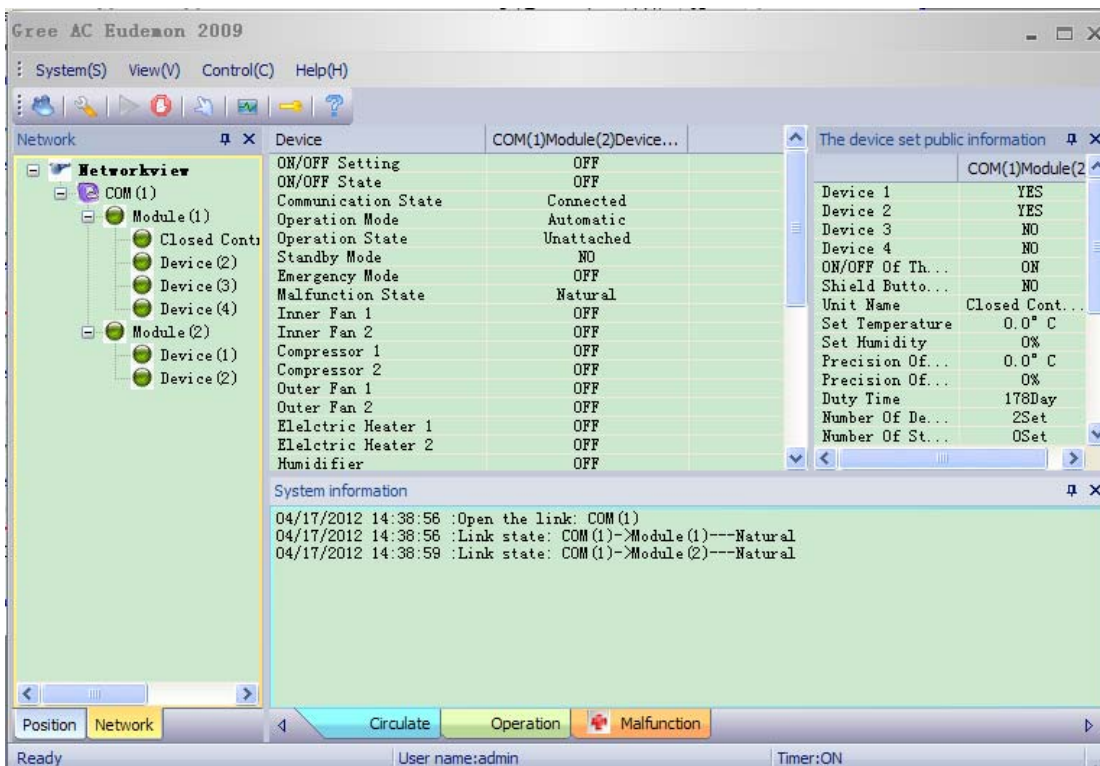

Menu: consist of “system”, “view”, “control” and “help” these four commands, there’s drop-down menu for every command to realize setting, operation, management and help

viewing. The screenshot of every drop-down menu is as following:

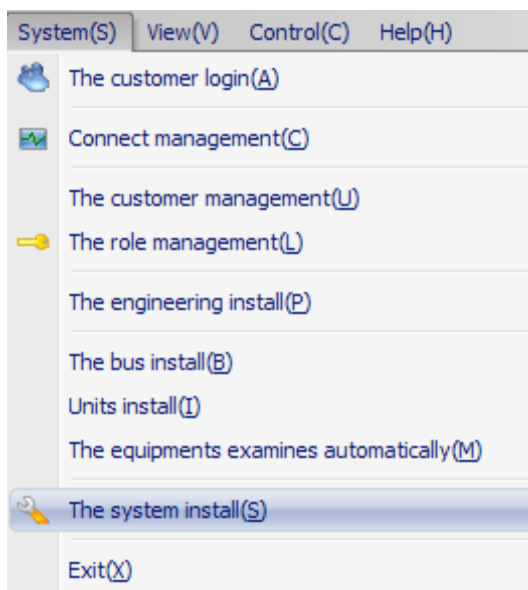

“system”

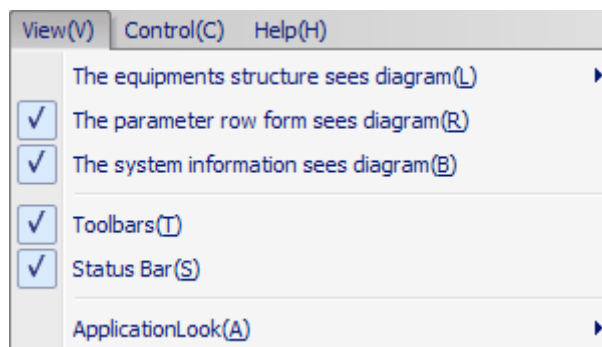

“view”

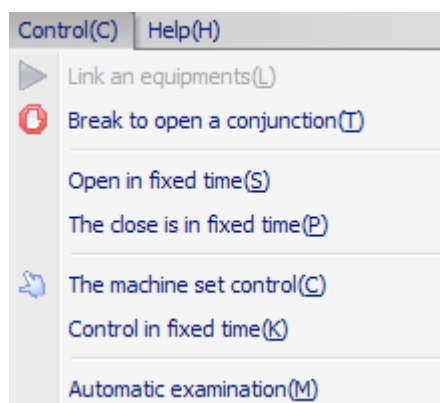

“control”

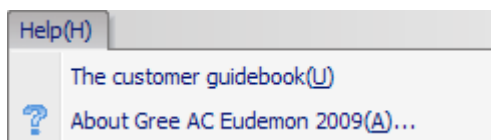

“help”

Tool: The buttons on “tool bar” are those setting and operation usually used in main menu. From the left to right are: the customer login, system configuration, connect, disconnect, unit control, connection management, about.

Network view: clearly show the project structure in “network” and “position” two ways. Select “network” to show the project topology structure; select “position” to show actual position of the project (e.g., floors and rooms where the unit is located).

Parameter view: consist of unit information and equipment information. Unit information shows the information of main module during modular operation, equipment information shows related parameter of selected equipment.

System information: consist of “Circulate”, “Operation” and “Malfunction”, separately shows the history record of running, operation and malfunction.

4.4 Unit and equipment management

4.4.1 Add unit and equipment

Click Main Menu->System->The equipments examines automatically, the software can find the added equipment.

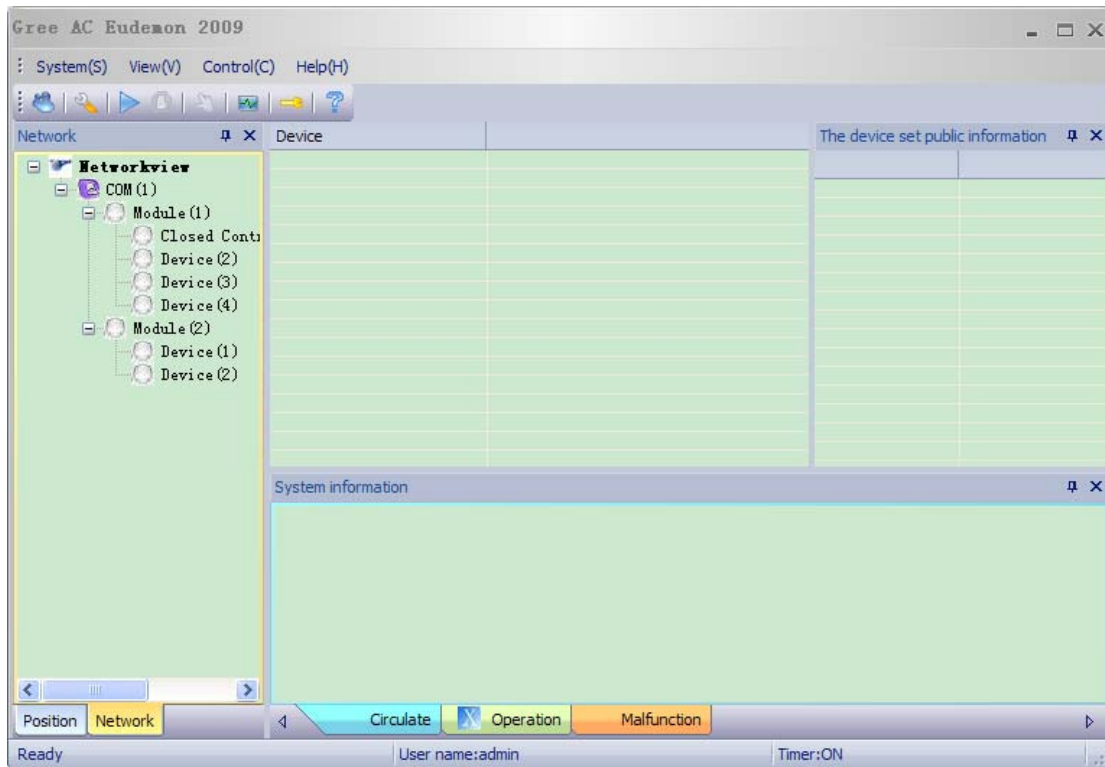



After self-checking is completed, the result will be showed on “network” of “network view”. If the result is conflict with present equipment, following dialog box will be popup and user has to select one of the result (it is advised to select the last self-checking result).

Note: main module could be connected with maximumly four submodules. During self-checking, no matter if there's submodule, once the system is connected, it could be inspected and showed in network view. If no submodule exists, it will show communication malfunction.

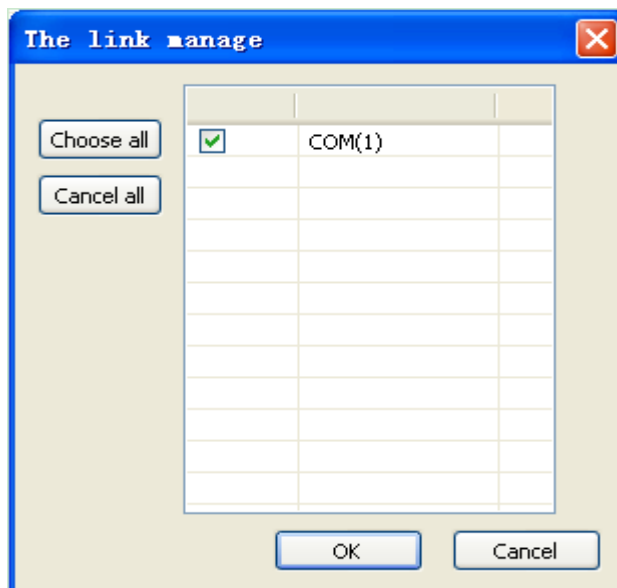
Click Main Menu->System->Connect management, (COM1 is applied in this example) and then click "OK".



Click Main Menu->Control->Link an equipments , the system will start checking according to saved connection. Related parameter will be displayed if the communication is normal.

Click Main Menu->Control->Break to open a conjunction , the system will stop monitoring to all the equipments.

4.4.2 Project information

Before monitoring, users have to select a project. Click Main Menu->System->The engineering install and the following interface will show. Fill in the project information, click “update” and “OK” to confirm.

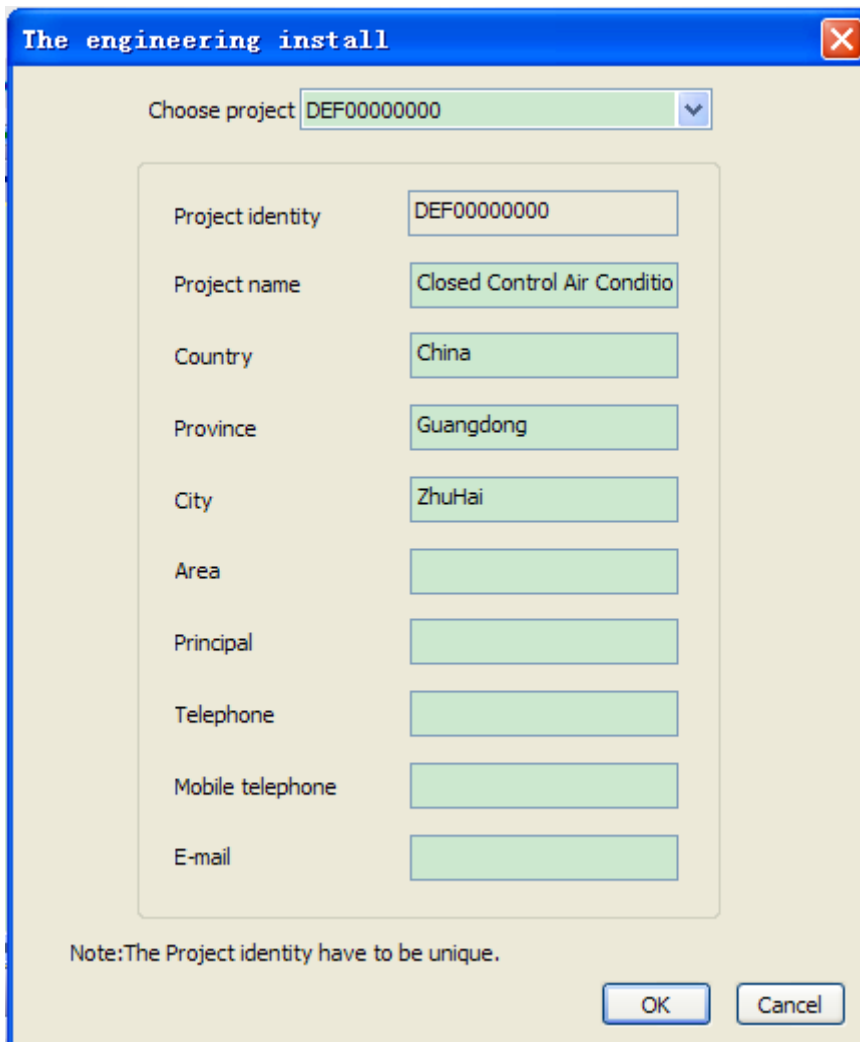

The screenshot shows a dialog box titled "The engineering install" with a close button (X) in the top right corner. The dialog contains a "Choose project" dropdown menu with "DEF00000000" selected. Below this is a form with the following fields:

Project identity	DEF00000000
Project name	Closed Control Air Conditio
Country	China
Province	Guangdong
City	ZhuHai
Area	
Principal	
Telephone	
Mobile telephone	
E-mail	

At the bottom of the dialog, there is a note: "Note: The Project identity have to be unique." and two buttons: "OK" and "Cancel".

4.4.3 Installation information configuration

Unit name: normally refer to the places where the AC installed, like “living room”,

“bedroom”, it is named by user.

After the equipment is added, user can specify the building, floor and room according to actual installation position for convenient monitoring. The unit information can be review at “position” of “network view” in main interface. Click Menu->System->Units install Configuration and the following interface will appear.

Add unit: after the information of building, floor, room and description is filled in, select the equipment need added in “the equipment haven’t yet define” frame and click , following dialog box will be popup. Fill in unit name and click “OK”, that equipment will be displayed in “The equipments have defined”, click “add” to finish the operation.

Delete unit: select the unit need delete in the drop-down list and click “delete”.

Note: same unit name cannot be added for different equipments.

4.4.4 Unit and equipment names

”Software’s default name: “module (address number)” for unit/main module, “equipment (address number)” for submodule.

Right click equipment and select “rename” to input name in popup dialog box, click “OK” to confirm. Same to rename the network view, equipment information and malfunction record.

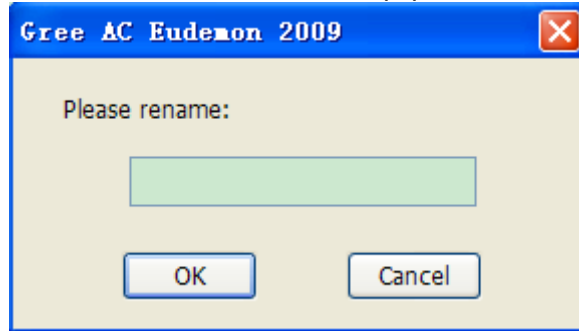

Note: address number could not be modified or deleted by renaming.

4.5 Parameter control

4.5.1 Parameter setting

The unit could be controlled by this system, click Main Menu->Control->The machine set control (or use context menu in network view, or click  in tool), the system will popup the control interface of present selected equipment, as following picture. Well set every parameter and click “OK” to control.

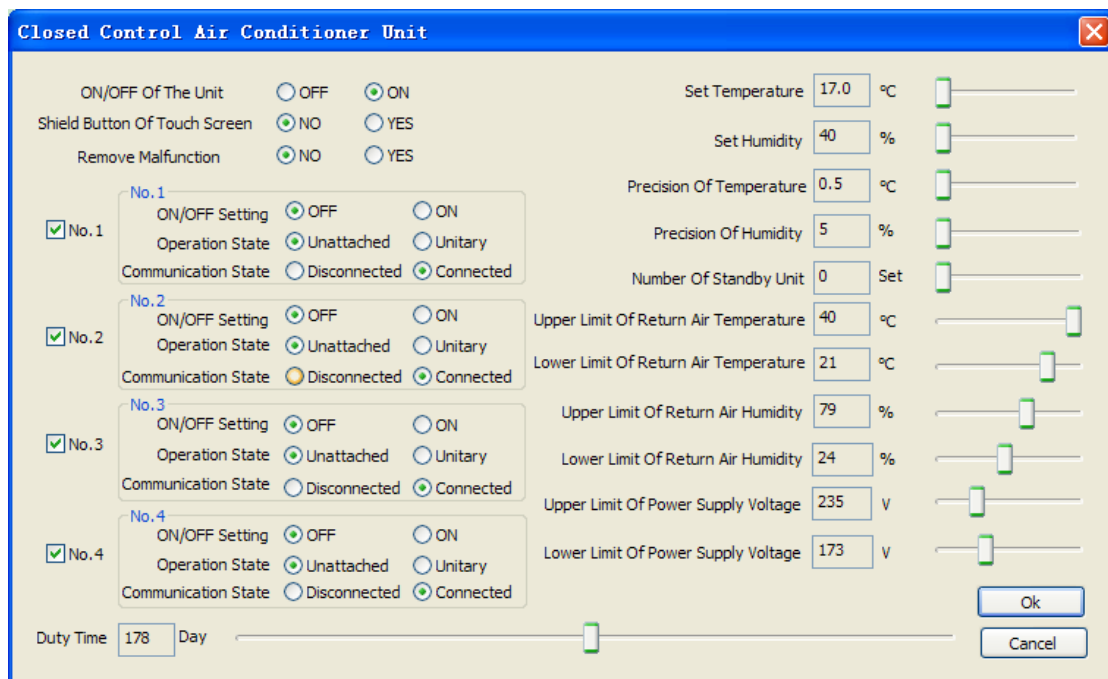

Control the main parameter of unit (main module) and equipment (submodule) through this interface.

Touch screen": once select "shield" and send command, the touch screen of main module could be shielded and "touch screen shielded" will be displayed on homepage of touch screen, then the parameter could not be set through touch screen. Select "not to shield screen" and send command to delete the shielding of screen.

"Clear malfunction": when unrecoverable malfunction occurs, the malfunction could be cleared and the unit could be reset by sending this command.

When there's no equipment (submodule) in network view, the related setting button will be ashing.

When select "disconnect" for communication status, related status button like ON/OFF setting will be ashing. After the command is sent, the parameter of equipment (submodule) will still exist in "network view" but not in "equipment parameter view".

4.5.2 Timer control

Click Main Menu->Control-> Control in fixed time (or use context menu in network view), following dialog box will be popped up.

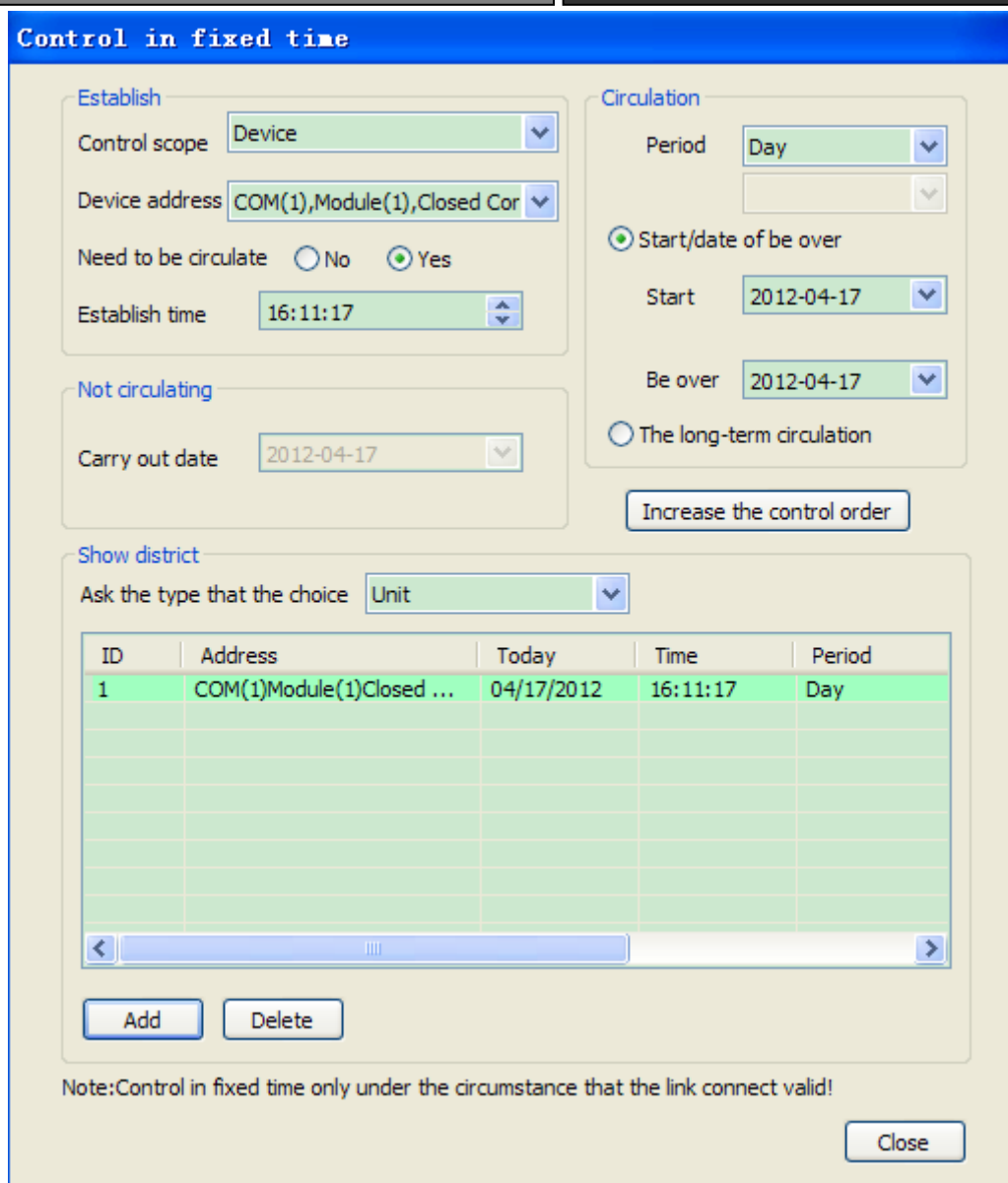

Timer adding: set related timer parameter, add control command and click “add” to confirm.

Timer deleting: select timer command in “view section” and click “delete” to confirm.

All timer controls could be showed at “view section”, if one of the timer command is overtime, it will marked with green. Check according to date or equipment is optional for users.

Note: To successfully set timer control, make sure the system is communicating with the equipment and timer switch is ON when setting. The status of timer switch could be checked in status bar, see following picture:



Timer on: click main menu -> control -> timer on; Timer off: click main menu -> control -> Timer off.

4.6 Running parameter view

4.6.1 Unit and equipment running parameter

Click main module (unit) in network view during running communicating status of software, related parameter of main module and its submodule will be displayed, see following picture:

Device	COM(1)Module(1)Closed...	COM(1)Module(1)Device...	COM(1)Module(1)Device...	CC ^	The device set public information	+	X
ON/OFF Setting	OFF	OFF	OFF		Device 1	YES	
ON/OFF State	OFF	OFF	OFF		Device 2	YES	
Communication State	Connected	Connected	Connected		Device 3	YES	
Operation Mode	Automatic	Automatic	Automatic		Device 4	YES	
Operation State	Unattached	Unattached	Unattached		ON/OFF Of Th...	ON	
Standby Mode	NO	NO	NO		Shield Butto...	NO	
Emergency Mode	OFF	OFF	OFF		Unit Name	Closed Cont...	
Malfunction State	Natural	Natural	Natural		Set Temperature	0.0° C	
Inner Fan 1	OFF	OFF	OFF		Set Humidity	0%	
Inner Fan 2	OFF	OFF	OFF		Precision Of...	0.0° C	
Compressor 1	OFF	OFF	OFF		Precision Of...	0%	
Compressor 2	OFF	OFF	OFF		Duty Time	178Day	
Outer Fan 1	OFF	OFF	OFF		Number Of De...	4Set	
Outer Fan 2	OFF	OFF	OFF		Number Of St...	0Set	
Elelctric Heater 1	OFF	OFF	OFF		Upper Limit ...	40° C	
Elelctric Heater 2	OFF	OFF	OFF		Lower Limit ...	21° C	
Humidifier	OFF	OFF	OFF		Upper Limit ...	79%	
Water-in Valve Of Hu...	OFF	OFF	OFF		Lower Limit ...	24%	
Drain Valve Of Humid...	OFF	OFF	OFF		Upper Limit ...	235V	
Dehumidifying Valve	OFF	OFF	OFF		Lower Limit ...	173V	
By-pass Valve	OFF	OFF	OFF		Operation Vo...	226V	
Return Air Temperature	0.0° C	0.0° C	0.0° C		Operation Vo...	226V	
Return Air Humidity	0%	0%	0%		Operation Vo...	226V	
Humidifying Current	0.0A	0.0A	0.0A		Return Air T...	24.9° C	
Discharge Temperat...	0° C	0° C	0° C		Return Air H...	55%	
Evaporator Inlet Tub...	0° C	0° C	0° C				
Evaporator Outlet Tu...	0° C	0° C	0° C				
Discharge Temperat...	0° C	0° C	0° C				
Evaporator Inlet Tub...	0° C	0° C	0° C				
Evaporator Outlet Tu...	0° C	0° C	0° C				

Click submodule, only the parameter of that submodule (equipment) and its main module (unit) will be displayed in equipment parameter view:

Device	COM(1)Module(1)Closed...	The device set public information	+	X
ON/OFF Setting	OFF	Device 1	YES	
ON/OFF State	OFF	Device 2	YES	
Communication State	Connected	Device 3	YES	
Operation Mode	Automatic	Device 4	YES	
1 Air Conditioner (1)	Unattached	ON/OFF Of Th...	ON	
Standby Mode	NO	Shield Butto...	NO	
Emergency Mode	OFF	Unit Name	Closed Cont...	
Malfunction State	Natural	Set Temperature	0.0° C	
Inner Fan 1	OFF	Set Humidity	0%	
Inner Fan 2	OFF	Precision Of...	0.0° C	
Compressor 1	OFF	Precision Of...	0%	
Compressor 2	OFF	Duty Time	178Day	
Outer Fan 1	OFF	Number Of De...	4Set	
Outer Fan 2	OFF	Number Of St...	0Set	
Elelctric Heater 1	OFF	Upper Limit ...	40° C	
Elelctric Heater 2	OFF	Lower Limit ...	21° C	
Humidifier	OFF	Upper Limit ...	79%	
Water-in Valve Of Hu...	OFF	Lower Limit ...	24%	
Drain Valve Of Humid...	OFF	Upper Limit ...	235V	
Dehumidifying Valve	OFF	Lower Limit ...	173V	
By-pass Valve	OFF	Operation Vo...	226V	
Return Air Temperature	0.0° C	Operation Vo...	226V	
Return Air Humidity	0%	Operation Vo...	226V	
Humidifying Current	0.0A	Return Air T...	24.9° C	
Discharge Temperat...	0° C	Return Air H...	55%	
Evaporator Inlet Tub...	0° C			
Evaporator Outlet Tu...	0° C			
Discharge Temperat...	0° C			
Evaporator Inlet Tub...	0° C			
Evaporator Outlet Tu...	0° C			

When communication of submodule is disconnected but still displayed in “network view”, its parameter will be no longer displayed in “equipment parameter view”.

When communication of main module (unit) is disconnected, the data in interface will no longer be updated and “overtime” will be reminding in running record of system information view.

4.6.2 Malfunction display

During running and communication of monitoring software, if malfunction of the unit or submodule (equipment) is detected, the related malfunction information will be displayed in “malfunction record” of “system information”.

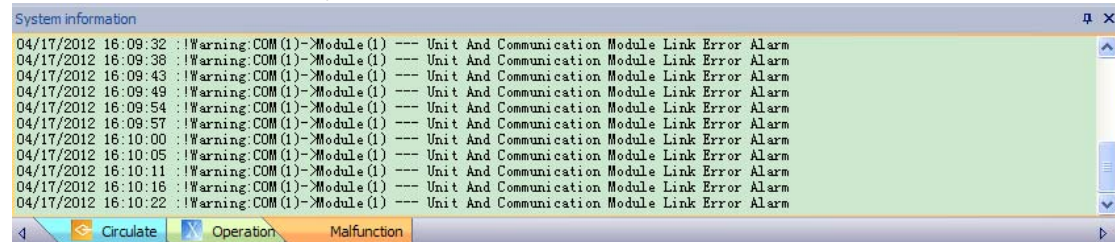

Please see appendix for detailed malfunction list.

4.7 User and role management

User: one user might occupy several roles.

Role: combination of some permissions

4.7.1 User management

The customer management can add, modify and delete user. Click Main Menu->System->The customer management and the following interface will show.

The screenshot shows a window titled "The customer management" with a close button in the top right corner. The window is divided into two main sections: "Static" and "All User".

Static Section:

- User Name:** A text input field containing "sun".
- Old Password:** An empty text input field.
- Password:** An empty text input field.
- Confirm a password:** An empty text input field.
- The role choose:** A table with a checked checkbox and the text "Administrator".

<input checked="" type="checkbox"/>	Administrator
<input type="checkbox"/>	
<input type="checkbox"/>	
<input type="checkbox"/>	

All User Section:

- A list box containing the text "admin".

Buttons:

- At the bottom left of the "Static" section: "Add", "Modify Password", and "Delete".
- At the bottom right of the window: "Close".

Add user: fill a different name with password and user, then click "add".

Modify password: select a user in "all users", type in the original password and new password, click "modify password".

Delete user: Select a user in "all users" and click "delete"

4.7.2 User management

Users having the rights of "The customer management" can add and delete role. Click Menu->System->The role management and the following interface will appear.

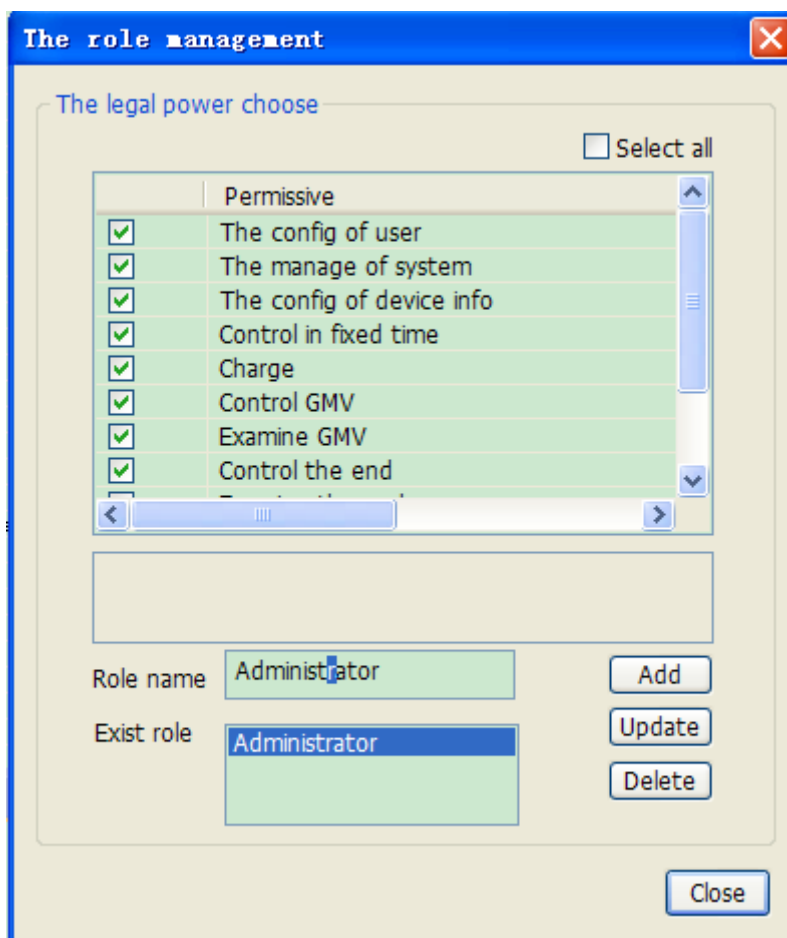

Add role: select permission in permissions list, fill in role name and click “add”.

Delete role: select a role in “role list” and click “delete”.

Note: the user is using cannot be deleted.

4.8 Others

4.8.1 Information inquiry

Click main menu -> help -> about Gree AC Eudemon 2009, following dialog box will be popped up.

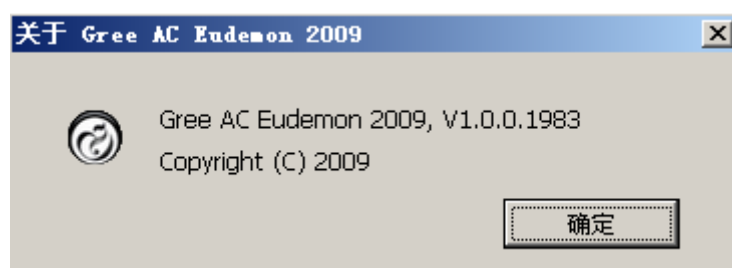

III Maintenance

1. Malfunction List

Malfunction	Signal Source	Control logic
Power Error	Phase reversal protector	When phase sequence has malfunction for continuous 3 seconds, the complete unit will stop and all loads will be turned off (without restriction of set delay time). The corresponding error code will be displayed on display and alarm will be given out. Reset or de-energize the unit to clear the error code.
Alarm of overheating of return air	Probe of temp and humidity of return air	In auto mode, when indoor fan of each module has operated for over 15 min.(3 seconds for quick test), and return air temperature is higher than the upper limit for continuous 30 seconds, the corresponding malfunction code will be displayed on display and also the alarm will be given out. The unit will keep running. Reset the unit or detect that such signal has disappeared for 3 minutes (3 seconds for quick test), the malfunction code will be removed. If the unit stops for other malfunction during this course, the unit makes a judgment again.
Alarm of low temperature of return air	Probe of temp and humidity of return air	In auto mode, when indoor fan of each module has operated for over 15 min.(3 seconds for quick test), and return air temperature is higher than the lower limit for continuous 30 seconds, the unit will treat the malfunction as same as the malfunction of overheating of return air. (If a module has malfunction of probe of return air, the detection of the overheating of return air will be shielded).
Alarm of high humidity of return air	Probe of temp and humidity of return air	In auto mode, when indoor fan of each module has operated for over 15 min. (3 seconds for quick test), and return air humidity is higher than the upper limit for continuous 30 seconds, the unit will treat the malfunction as same as the malfunction of overheating of return air. (If a module has malfunction of probe of return air, the detection of the overheating of return air will be shielded).
Alarm of low humidity of return air	Probe of temp and humidity of return air	In auto mode, when indoor fan of each module has operated for over 15 min.(3 seconds for quick test), and return air humidity is higher than the lower limit for continuous 30 seconds, the unit will treat the malfunction as same as the malfunction of overheating

		of return air. (If a module has malfunction of probe of return air, the detection of the overheating of return air will be shielded).
High temperature protection for discharge of compressor	Discharge temp sensor	When compressor operates, if compressor discharge temperature is higher than set value for continuous 30 seconds, compressor and corresponding loads (valve for dehumidifying and gas by-pass valve) will be turned off without being restricted by set delay time. The outdoor fan will be turned off 5 seconds later, the corresponding malfunction will be displayed on display and alarm also will be given out. After 3 minutes, if discharge temp is lower than 90 °C, the malfunction will be removed and the system will resume operation without being restricted by set delay time. If discharge temp $\geq 90^{\circ}\text{C}$, or the protection occurs 3 times during 1 hour, there is such malfunction and the system can't automatically resume operation. The corresponding malfunction will be displayed and alarm will be given out. Reset or de-energize the unit to clear the malfunction signal.
Low pressure protection of compressor	Pressure controller	When compressor operates for over 15 seconds and the low pressure signal is detected during set delay time, compressor and corresponding loads will be turned off without being restricted by set delay time. The outdoor fan will be turned off 5 seconds later, the corresponding malfunction will be displayed on display and alarm also will be given out. After 3 minutes, if low pressure controller is automatically reset, the compressor will automatically operate without being restricted by delay time and the malfunction will be removed. If the malfunction can't be removed automatically, or the protection occurs 3 times during 1 hour, there is such malfunction and the operation can't be automatically resumed. The corresponding malfunction code will be displayed and alarm will be given out. Reset or de-energize the unit to clear the malfunction signal.
Low pressure protection of compressor	Pressure controller	When high pressure signal is detected for continuous 3 seconds, compressor and corresponding loads will be turned off without being restricted by set delay time. The outdoor fan will be turned off 5 seconds later, the corresponding malfunction will be displayed on display and alarm also will be given out. The malfunction can't be automatically removed. Reset or de-energize the unit

		to clear the malfunction signal.
Overload protection of compressor	Overcurrent protector	When overload of compressor is detected for continuous 3s, compressor and corresponding loads will be turned off without being restricted by set delay time. The outdoor fan will be turned off 5 seconds later, the corresponding malfunction will be displayed on display and alarm also will be given out. After 3 minutes, if overload of compressor is automatically removed, the compressor will automatically operate without being restricted by delay time and the malfunction signal will be removed. If the malfunction can't be removed automatically, or the protection occurs 3 times during 1 hour, there is such malfunction and the operation can't be automatically resumed. The corresponding malfunction will be displayed and alarm will be given out. Reset or de-energize the unit to clear the malfunction signal.
Overload protection of indoor fan	built-in guard wire of indoor fan	If overload of indoor fan is detected for continuous 3 seconds, the complete unit will stop and all loads will be turned off without being restricted by delay time. Corresponding malfunction will be displayed and alarm will be given out. Reset or de-energize the unit to clear the malfunction signal.
Overheating protection of electric heater	Thermostat	When thermostat is off for continuous 3s, corresponding electric heater will be turned off and it can't automatically resume operation. Corresponding malfunction will be displayed and alarm will be given out. Reset or de-energize the unit to clear the malfunction signal.
Low air pressure malfunction of indoor fan	Air pressure switch	When indoor fan operate for 10s, if the signal of activation of air switch is detected for continuous 3s, the complete unit will stop and all loads will be turned off without being restricted by set delay time.
Alarm of blocking filter	Air pressure switch	When indoor fan operate for 10s, if the signal of activation of air switch is detected for continuous 3s, the corresponding malfunction will be displayed and alarm will be given out without affecting other loads. When indoor fan operates, if air switch of filter works normally for continuous 1 min, the malfunction will be removed. Reset or de-energize the unit to clear the malfunction signal.
Malfunction of probe for return air	Probe of temp and humidity of return air	If detect that the probe for return air failures for continuous 1 min, indoor fan will operate when the unit is started up while it will be turned off when the unit is

		turned off. The compressor and corresponding load, electric heater and humidifier will be turned off according to manual turning off sequence. The outdoor fan will be turned off in 5s. The corresponding malfunction will be displayed and alarm will be given out. If the probe for return air is automatically resume normal work, the compressor, electric heater and humidifier will resume operation and malfunction signal will be removed. If the malfunction is not removed, pressing reset button will not work. Manually turn off and de-energize the unit to clear the malfunction signal.
Low current malfunction of humidifier	Current transformer	When humidifier operates (HUMID closes), if current for humidifying is lower than 1 A for continuous 10 min (feed valve may not turned on/discharge valve may not turned off/ short circuit may occurs between electrodes/ purified water may be used), switch off the humidifier without affecting other loads. Corresponding malfunction will be displayed, and alarm will be given out. Manually turn off and de-energize the unit to clear the malfunction signal.
Drainage malfunction of humidifier	Current transformer	When humidifier operates (HUMID closes), if current for humidifying is lower than 1.3Iset for continuous 3 min, switch off the humidifier without affecting other loads. Corresponding malfunction will be displayed, and alarm will be given out. Manually turn off and de-energize the unit to clear the malfunction signal.
High water level protection of humidifier	High water level switch of humidifier	When humidifier operates (HUMID closes), if the signal of high water level is detected for continuous 20 min, switch off the humidifier without affecting other loads. Corresponding malfunction will be displayed, and alarm will be given out. Manually turn off and de-energize the unit to clear the malfunction signal.
Alarm for water on floor	Flooding switch	When signal from flooding switch is detected for continuous 30s (3s for quick test), the complete unit will stop and all loads will be turned off without being restricted by set delay time. Corresponding malfunction will be displayed, and alarm will be given out. Manually turn off and de-energize the unit to clear the malfunction signal.
Sub-module communication malfunction	Mainboard	If there is communication malfunction between sub-module and main module for 30s, the indoor fan will operate once the unit is started up while it will be turned off once the unit is turned off. Compressor, electric heater and humidifier will be turned off according to manual turning off sequence. Corresponding

		malfunction will be displayed, and alarm will be given out. Manually turn off and de-energize the unit to clear the malfunction signal.
Main module communication malfunction	Mainboard	If there is communication malfunction between sub-module and main module for 30s, the indoor fan will operate once the unit is started up while it will be turned off once the unit is turned off. Compressor, electric heater and humidifier will be turned off according to manual turning off sequence. Corresponding malfunction will be displayed, and alarm will be given out. If mainboard resume communication to touchable screen automatically, the unit will resume operation and malfunction signal will be removed. Manually turn off and de-energize the unit to clear the malfunction signal.
Communication malfunction of remote monitoring	Main board	If there is communication malfunction between main module and remote monitoring module, "remote monitoring" will disappear on homepage of screen and corresponding malfunction will be displayed on malfunction area of remote monitoring interface, along with "Buzz". The unit will keep operation. When communication is resumed, the malfunction will be automatically removed.
Customer linkage protection	Main board	If linkage signal is detected for continuous 30s (3s for quick test), the complete unit will be turned off without being restricted by set delay time. Manually turn off and de-energize the unit to clear the malfunction signal.
Fire alarm	Main board	If signal of fire alarm is detected for continuous 3s, the complete unit will stop without being restricted by set delay time. Corresponding malfunction will be displayed, and alarm will be given out. Reset or de-energize the unit to clear the malfunction signal.
Adhesion alarm of electric heating	AC contactor of electric heater	When electric heater is turned off and adhesion of AC contactor is detected for continuous 10s, if indoor fan is turned off, it will be turned on while if it operates, it will keep operating. Other load will normally work. Corresponding malfunction will be displayed, and alarm will be given out. It can't be automatically resume normal operation and pressing reset button will not work. De-energize the unit to clear the malfunction signal.
Discharge temp sensor/inlet pipe of evaporator	Temp sensor	If the temp sensor is short of open circuit for continuous 30s, compressor and corresponding loads will be turned off without being restricted by set delay time. Outdoor fan will be turned off in 5 seconds. Corresponding

temp sensor/outlet pipe of evaporator temp sensor malfunction		malfunction will be displayed, and alarm will be given out. If the malfunction is automatically removed, the compressor resumes operation and malfunction code will be removed. Select malfunction resetting or manually de-energize the unit to clear the malfunction signal. (Application range of discharge temp sensor: 20°C~149°C; Application range of other temp sensors: -40°C~127°C; Malfunction will be displayed when it goes beyond the range.
---------------------------------------------------------------	--	-------------------------------------------------------------------------------------------------------------------------------------------------------------------------------------------------------------------------------------------------------------------------------------------------------------------------------------------------------------------------------------------------------------------------------------------------------------

2. Troubleshooting

2.1 High Pressure Protection of Compressor

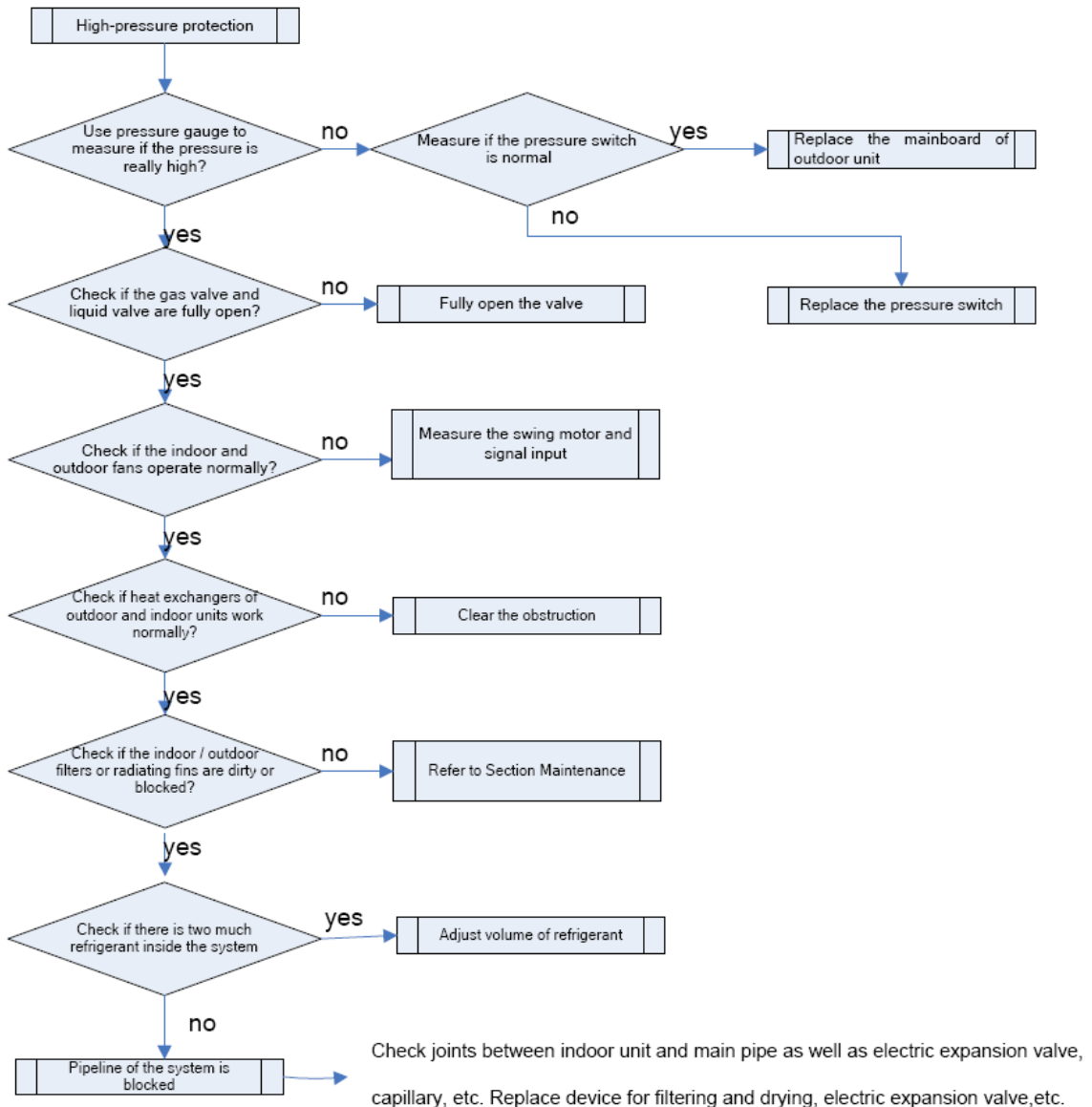

2.2 Low Pressure Protection of Compressor

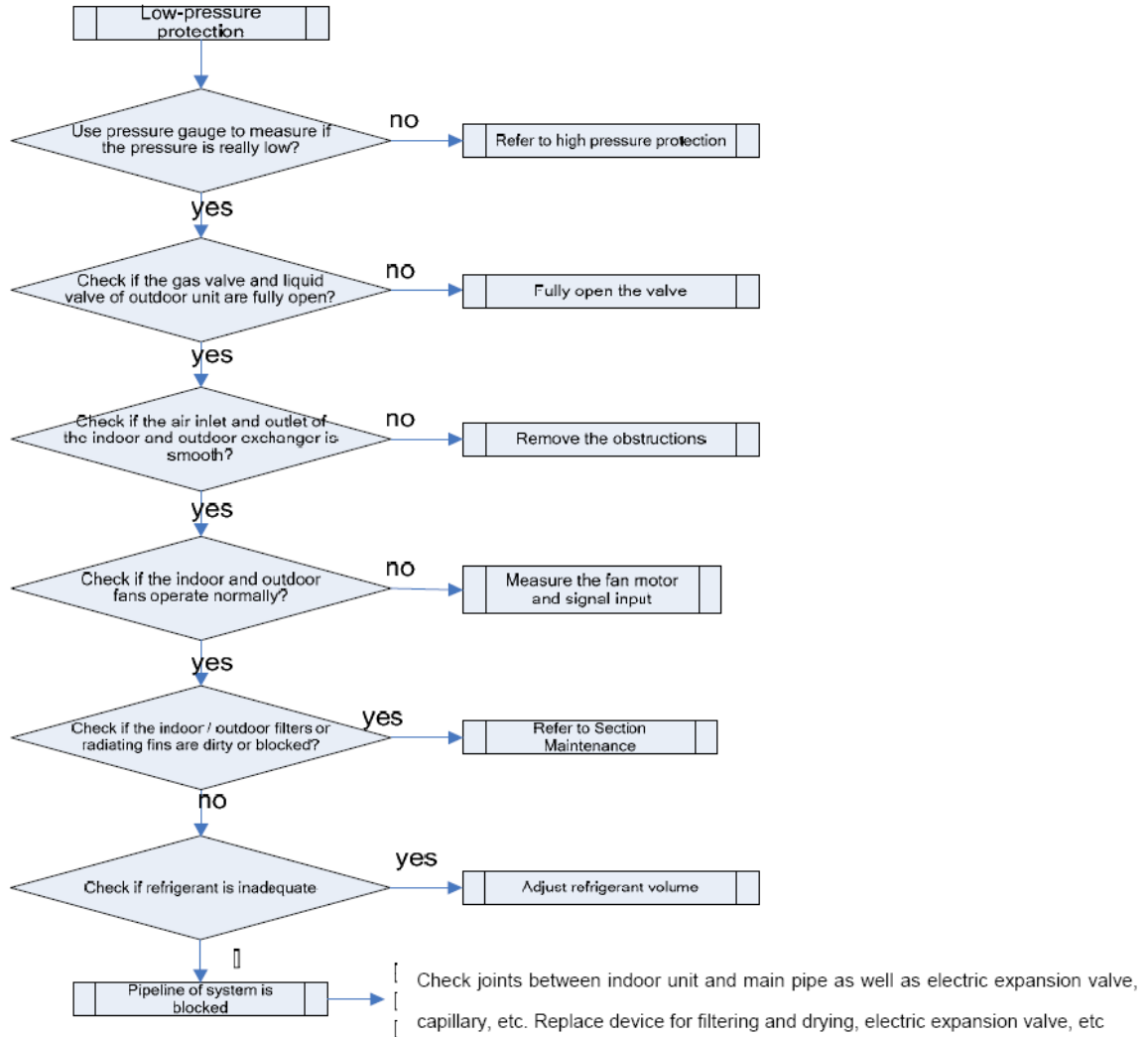

2.3 Discharge Temp Protection for Compressor

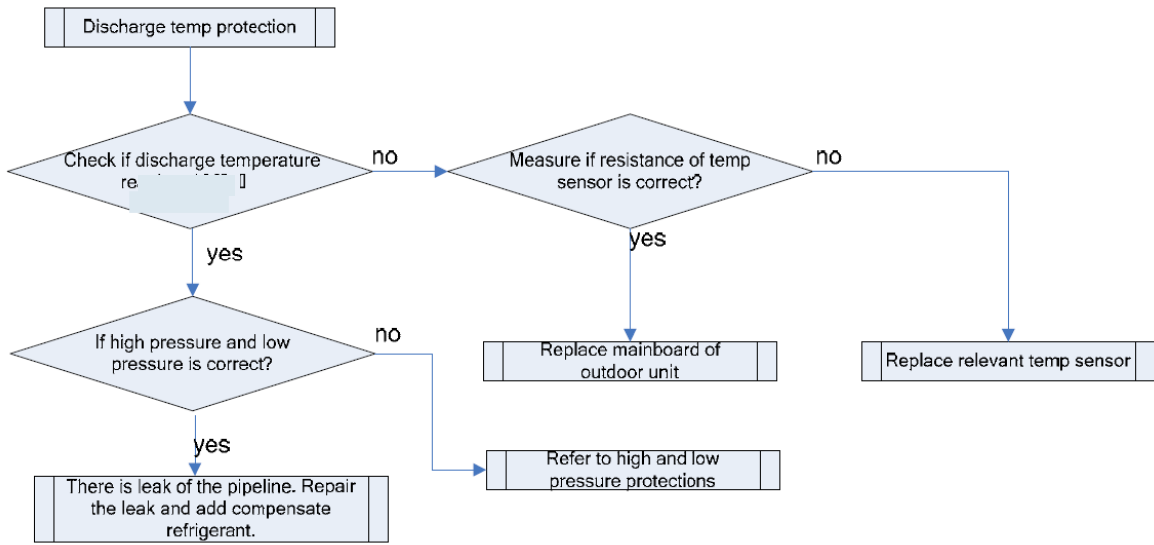

2.4 Overload Protection of Compressor

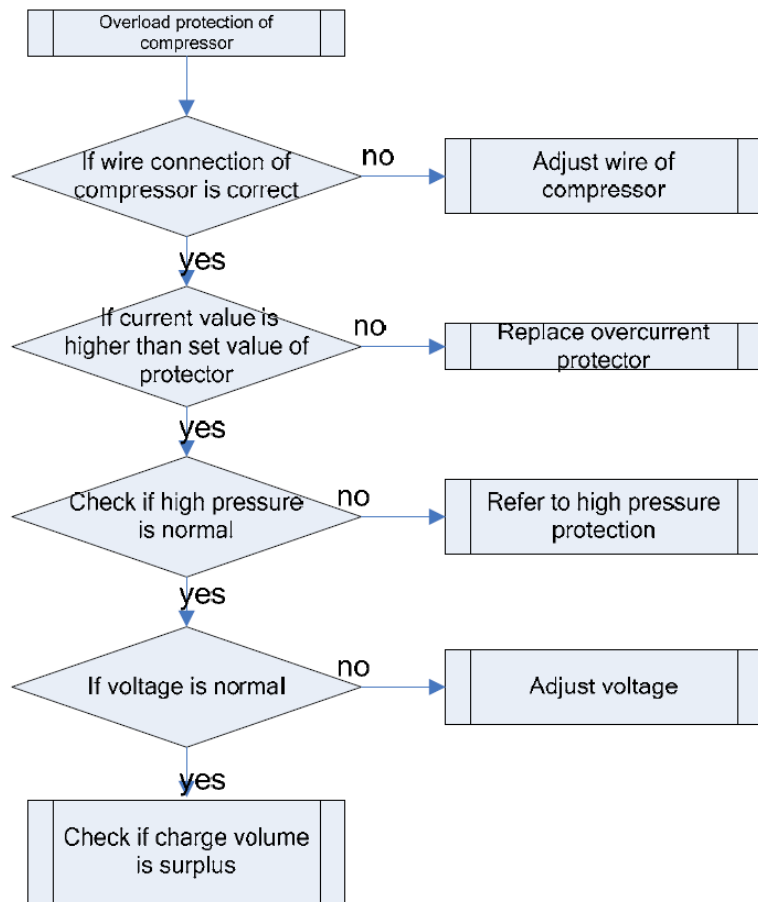

2.5 Overload Protection of Indoor Fan

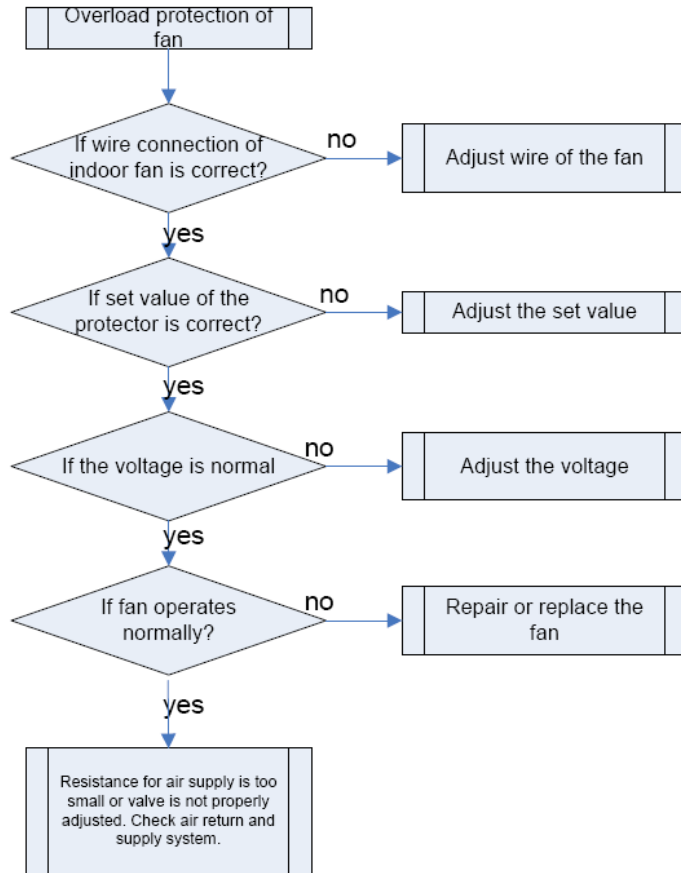

2.6 Temperature Protection of Electric Heater

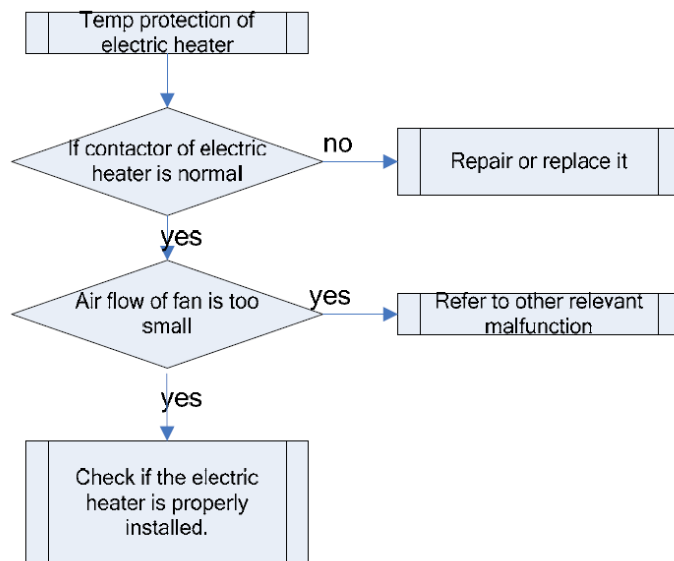

2.7 Low Current Malfunction, Drainage Malfunction and High Water Level Malfunction of Humidifier

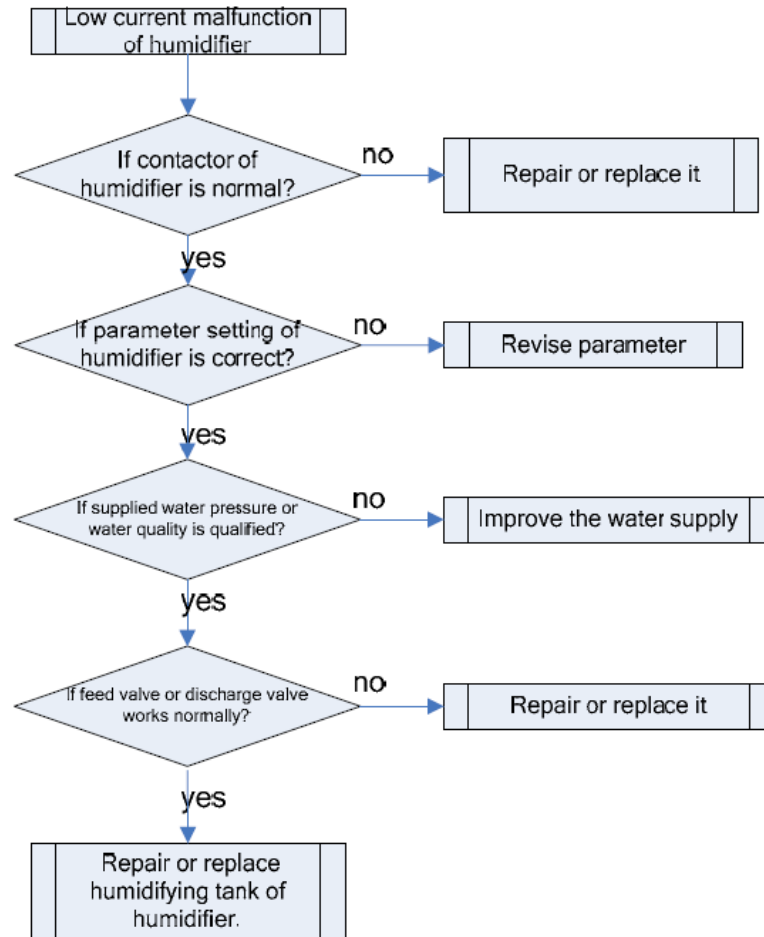

2.8 Low Air Pressure Malfunction of Indoor Fan

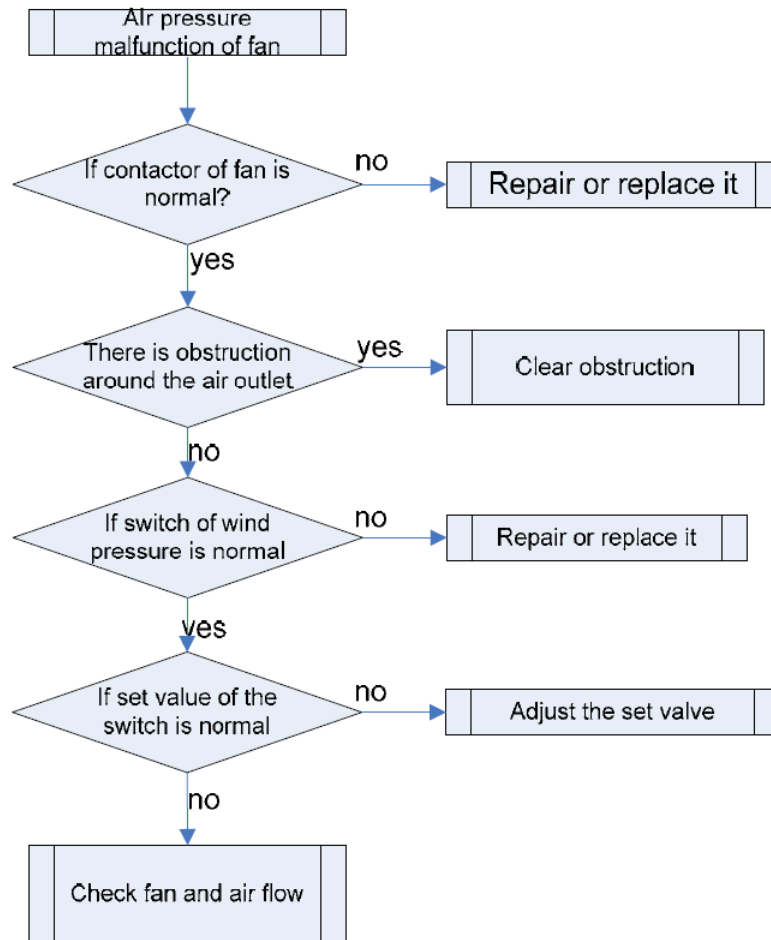

2.9 Alarm for Blocking Filter

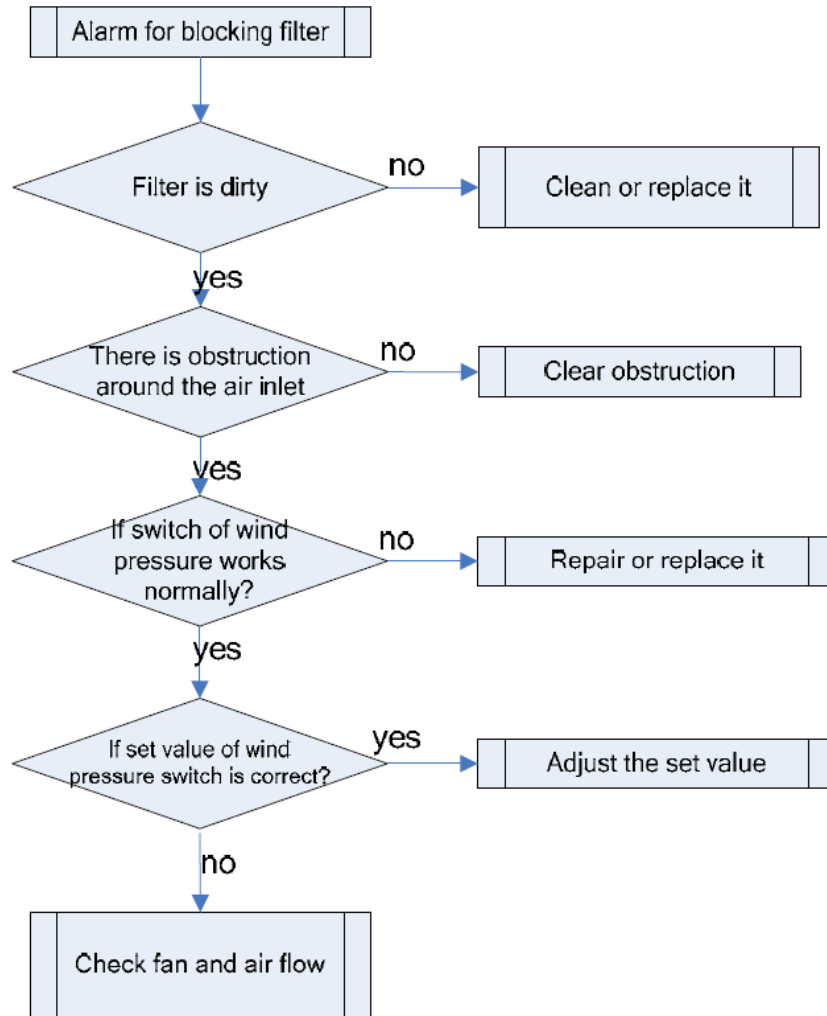

3. Case Study

Case 1

Malfunction Phenomenon: Low pressure protection occurs after the unit operates normally in cooling mode for a period of time.

Possible causes: pressure controller is abnormal; parameter setting of touch screen is abnormal; air return and supply are not smooth; pipeline is blocked (including expansion valve, filter, etc.).

Analysis of root cause: Firstly, check each set parameter and the set parameters are factory setting so there is no problem. Check if air flow around the air inlet and outlet is smooth and check if there is any obstruction. After inspection, it is found that there is no obstruction around the air inlet and outlet and air flow and air volume are normal. Check if wiring of pressure controller is normal. Check low pressure of the unit and the low pressure is 0.05MPa which is within the low pressure protection range. So there is no malfunction of pressure controller. Check the status of pipeline. Observe the pipe by viewing mirror and it is found that there is almost no liquid flowing through the mirror. The pipeline in front of the mirror may be blocked. After inspection of pipeline, it is found that the temperature difference between the front part and the rear part of the filter is huge but other pipes are normal. So we can get a conclusion that the filter is blocked. After replacing the filter, the unit resumes normal operation.

Conclusion: There are obstacles in the cooling system, which causes blockage of filter when the system is running.

Case 2

Malfunction Phenomenon: high water level protection of humidifier during debugging of the unit.

Possible causes:

- (1) High water level protector has malfunction;
- (2) Water discharge valve can't be started up;
- (3) Water inlet valve can't be turned off;
- (4) Current transformer is damaged;
- (5) Water quality is bad.

Analysis of root cause: Firstly, check if water level of humidifier tank is normal. Actually, the tank is full of water and there is high water level. Therefore, high water level protector doesn't have malfunction. Switch the unit to manual debugging mode by touchable screen. Manually turn off/on the valve of humidifier and it works normally. So there is no relevant malfunction. Then manually drain the water inside the tank of humidifier and then manually turn

on the humidifier. Measure current for humidifying and compare it with that in touchable screen. At the same time, observe water level of humidifier tank and status of valve on screen. In fact, the current measured is almost the same with that displayed on screen. So there is no malfunction of current transformer. With increase of water level inside the humidifier tank, the current value increases. When water valve is in off status on screen, current value is 3.7. When water level keeps increasing, the current value increases too. In that case, there is high water level alarm and the current value is 4.3. So we can get a conclusion that high water level alarm is caused due to small humidifying current as the humidifier tank is full of water which is incurred by small electric conductivity of water supplied.

Conclusion: When humidifying current is too low due to bad electric conductivity of water supplied or long operation of the humidifier, treat the water to improve its electric conductivity(eg, adding dissolving salt) so that the humidifier can normally operate.

Case 3

Malfunction Phenomenon:

In normal conditions, touchable screen shows warning “water on floor” and the unit can't be started up.

Possible causes:

- (1) Flooding switch is damaged;
- (2) Electrode is damaged;
- (3) Wiring is incorrect.

Possible causes: check if the power indicator of flooding switch is on. If not, it means there is no +12V power supplied for flooding switch. Check if the wiring of mainboard is correct. If it is correct, replace the flooding switch. When power indicator of flooding switch is on, check if malfunction indicator is on. If it is on, there is a malfunction. Open shell of flooding switch to check if electrode is short-circuited or the wiring terminal is oxidized. When malfunction is removed, the malfunction indicator will be off. Press reset button to clear the warning. If power indicator of flooding switch is on and malfunction indicator is off, the switch is ok. Check if wire connecting to mainboard is correct. If it is correct, replace the mainboard.

Conclusion: when touchable screen shows warning “water on floor”, the unit will stop and can't be started up, which may be incurred by oxidization of electrode, short circuit, malfunction of flooding switch or loose wiring of mainboard.

Case 4

Malfunction Phenomenon: the mainboard of controller doesn't work after energization and the communication indicator doesn't blink. Touch ON button on touchable screen, the outdoor unit doesn't operate.

Possible Causes:

- (1) Mainboard is burnt out;
- (2) Protective tube is damaged;
- (3) Wrong wiring

Possible causes: remove electric box to check the mainboard. If it is burnt out, the mainboard shall be replaced.

Check if protective tube breaks. If so, the protective tube shall be replaced. Check if null wire or live wire of power cord is short-circuited. If so, remove the malfunction and re-energize the unit.

Check if the wiring is correct according to wiring diagram. Check the conductivity of wire by universal meter.

Once the unit is energized, check if power indicators D3, D30 are bright. If they are bright, mainboard +5V is correct. Buzzer of mainboard will sound after energization. If it is not sound, the mainboard has malfunction and needs to be replaced. Check +5V、+12V、-12V by universal meter. If they are normal, transformer and rectifier circuit are normal, or else they need to be replaced. Check communication indicator D4 of mainboard. If D4 is blinking, the communication between mainboard 2 and mainboard 1 is normal. If communication indicator D12 blinks, communication between mainboard 2 and touchable screen is normal. If it is abnormal, check if the communication wire is connected correctly.

Conclusion: if null wire and live wire are short circuited, protective tube will break or mainboard will be burnt out. If wiring is loose or breaks, communication of mainboard will be abnormal and the unit will not operate.

4. Power Distribution of the Unit

4.1 Power Distribution Diagram

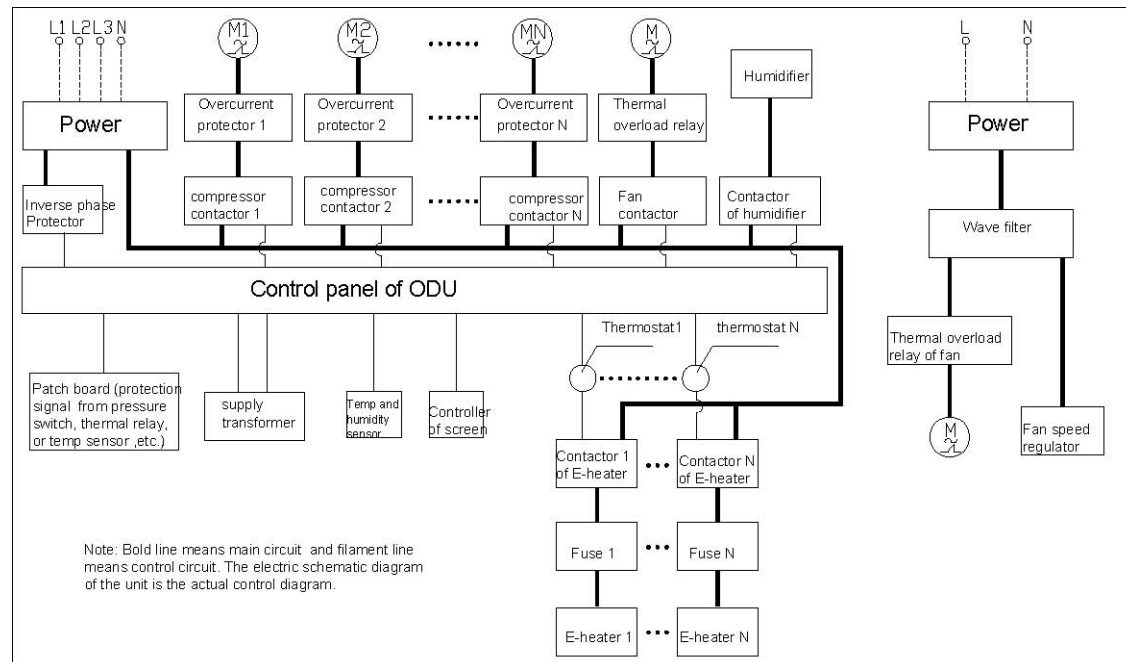

4.1.1 Phase Reversal Protector

- (1) Protection conditions: Input terminal of power supply for the protector is phase reversal;
- (2) Result of activation: The complete unit is de-energized and can't be turned on;
- (3) Treatment: Adjust wire sequence of power patch board. Check if the voltage of three-phase power is normal.

4.1.2 Thermal Overload Relay:

- (1) Protection conditions: Current of motor is huge and currents of three phases are not in balance. There is phase loss.
- (2) Result of activation: Overload protection of motor will be shown on wired controller;
- (3) Treatment: Check if winding of three phases of compressor is normal. If it's normal, turn on the unit again and check if the working current of motor is normal.

4.1.3 Thermostat:

- (1) Protection conditions: Temperature of controlled parts reaches the set value;
- (2) Result of activation: Contact of thermostat is on or off;

- (3) Treatment: During normal operation, when the temperature of a controlled part reaches the preset value, the temp sensor whose activation temperature is fixed or adjustable will cut on or off the circuit. It can be automatically or manually reset.

4.1.4 Overcurrent Protector of Compressor:

- (1) Protection conditions: Current of motor is huge and currents of three phases are not in balance. There is phase loss.
- (2) Result of activation: Overload protection of motor will be shown on wired controller;
- (3) Treatment: Check if winding of three phases of compressor is normal. If it is, turn on the unit again and check if the working current of compressor and system pressure are normal.

4.1.5 Fusible Cutout:

- (1) Protection conditions: Temperature of controlled parts reaches the set value;
- (2) Result of activation: Contact of fusible cutout is on or off;
- (3) Treatment: During normal operation, when the temperature of a controlled part reaches the preset value, the temp sensor whose activation temperature is fixed or adjustable will cut on or off the circuit. It can be automatically or manually reset.

4.1.6 AC contactor:

- (1) activation conditions: Coil of AC contactor is energized;
- (2) Result of activation: Main contact closes and load is started up.

4.2 Circuit Diagram (The circuit diagram is for reference only and the circuit diagram on the unit is the standard.)

4.2.1 Indoor Unit JKFD5XXX(I)

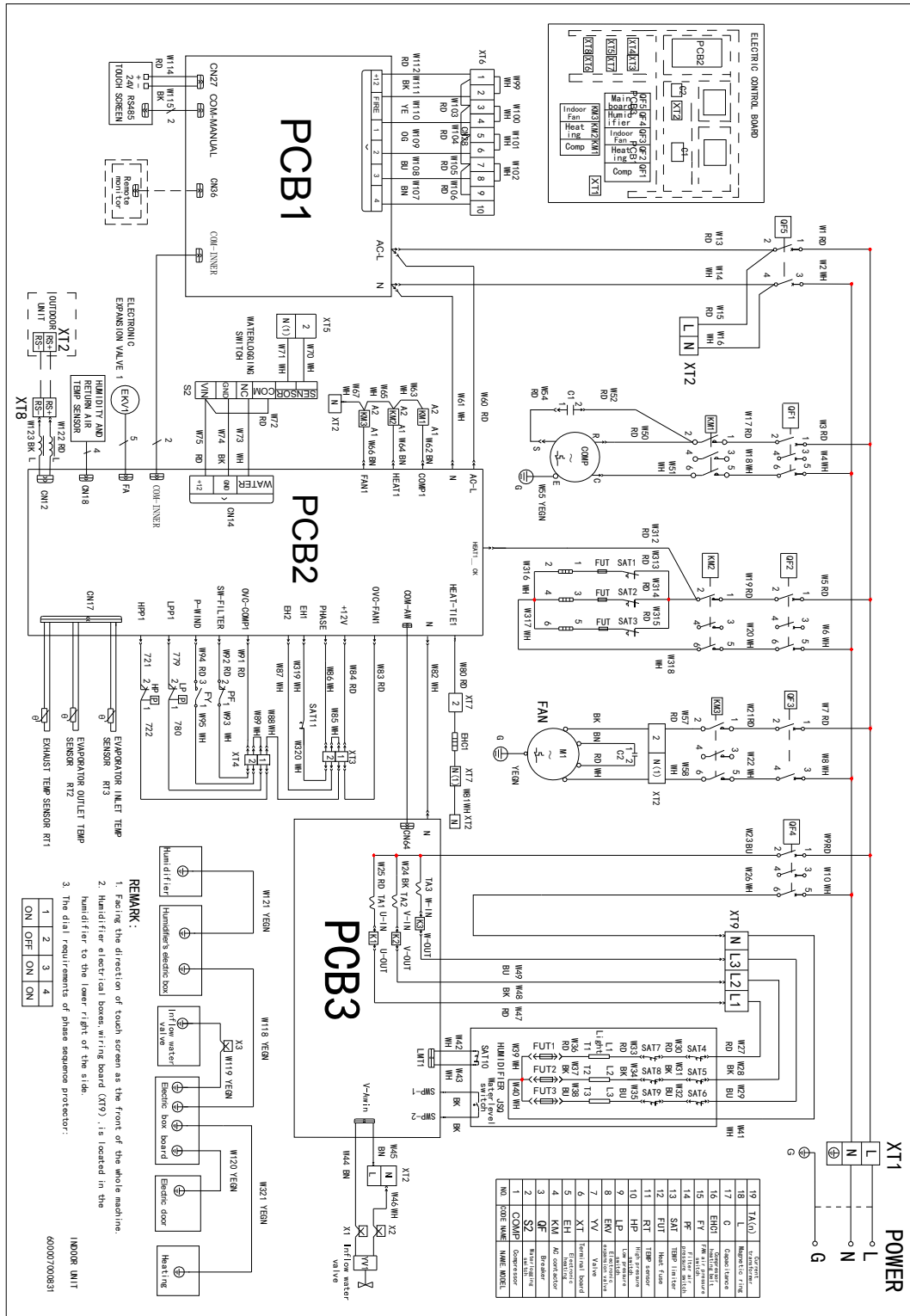

4.2.2 Indoor Unit JKFD7XXX(I)

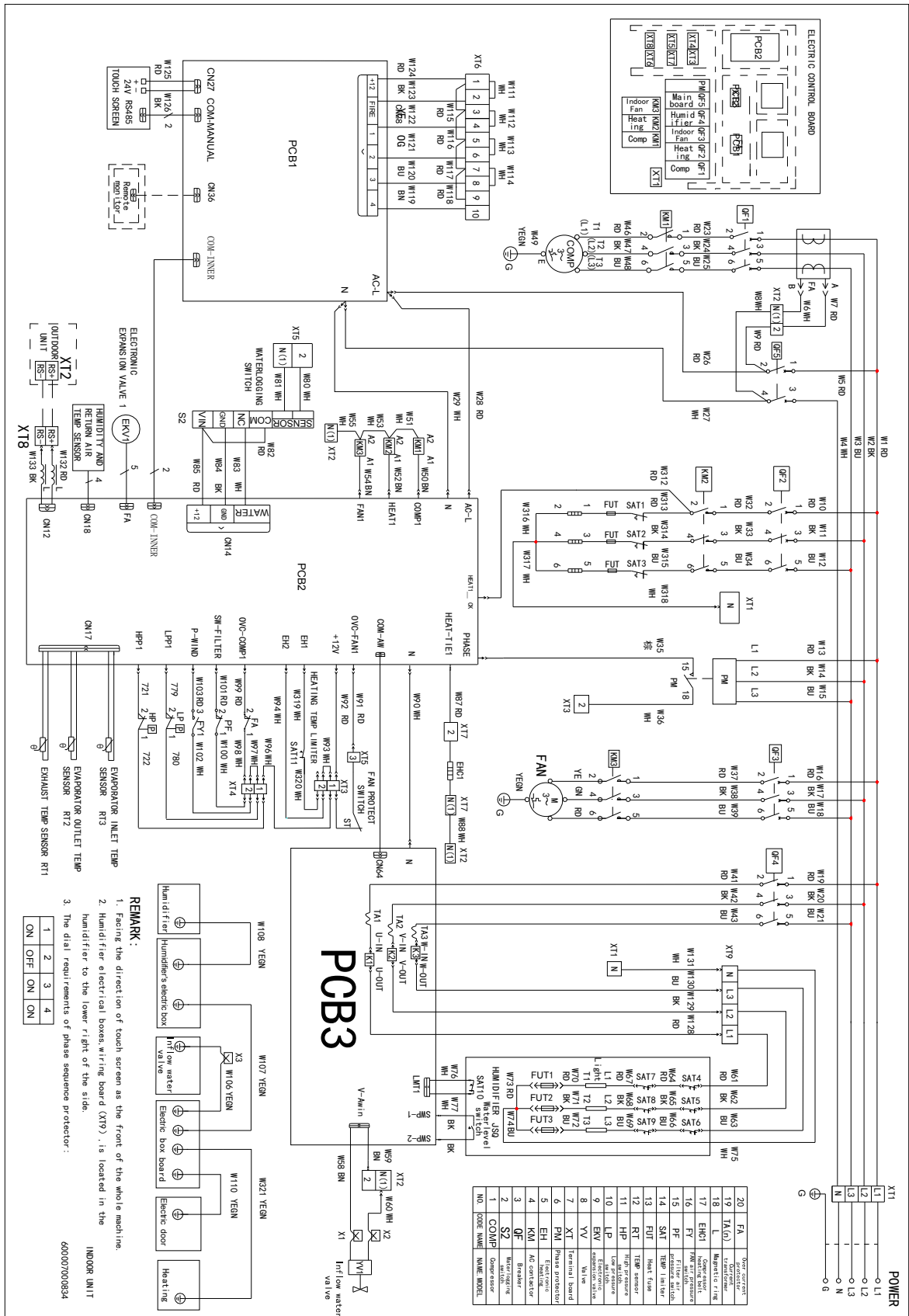

REMARK:

1. Facing the direction of touch screen as the front of the whole machine.
2. Humidifier electrical boxes, wiring board (X79) is located in the humidifier to the lower right of the side.
3. The dial requirements of phase sequence protector:

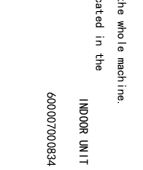

4.2.3 Indoor Unit JKFD15XXX(I)、JKFD20XXX(I)

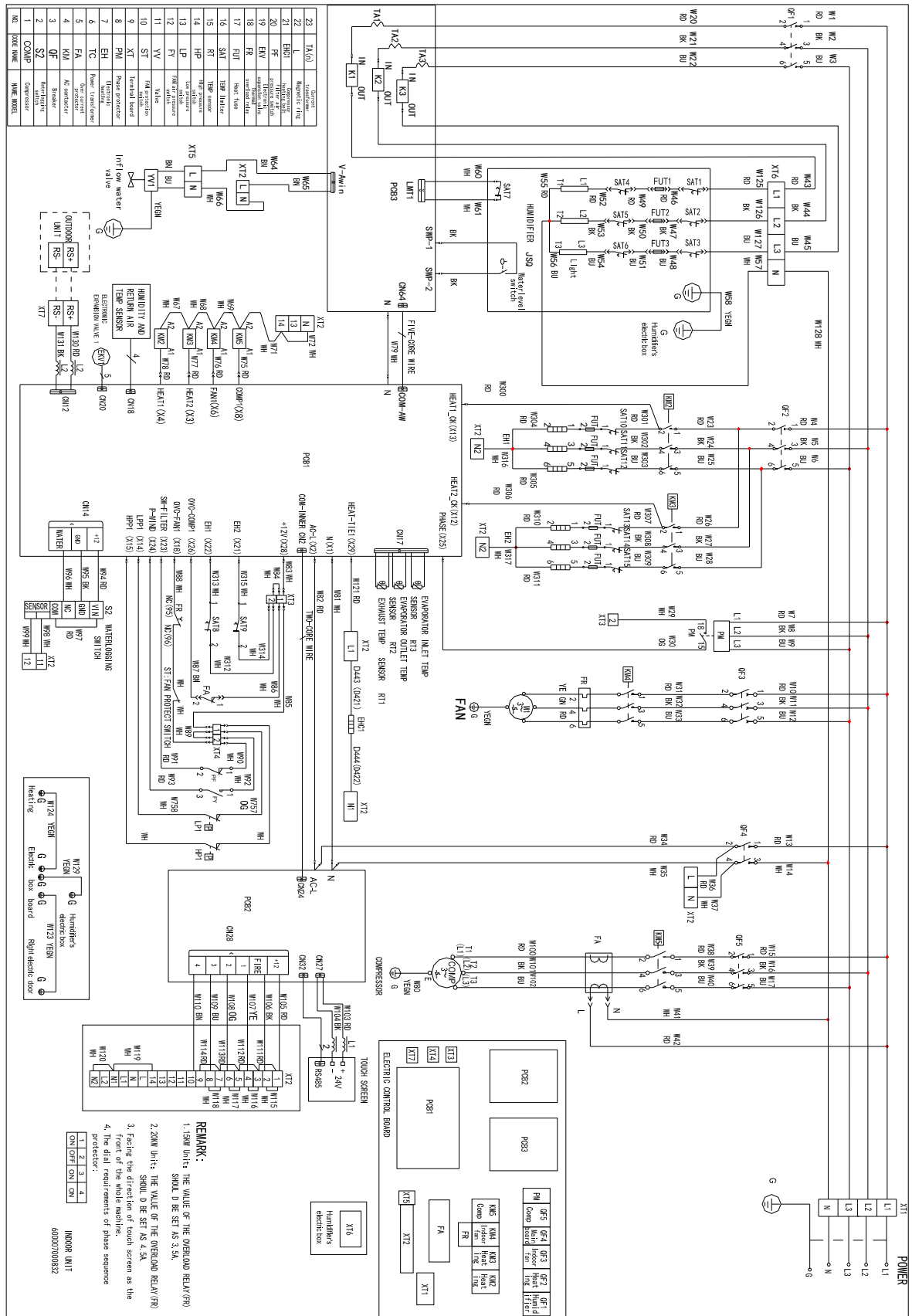

4.2.4 Indoor Unit JKFD25C2/Na-M(I)、JKFD25QS2/Na-M(I)

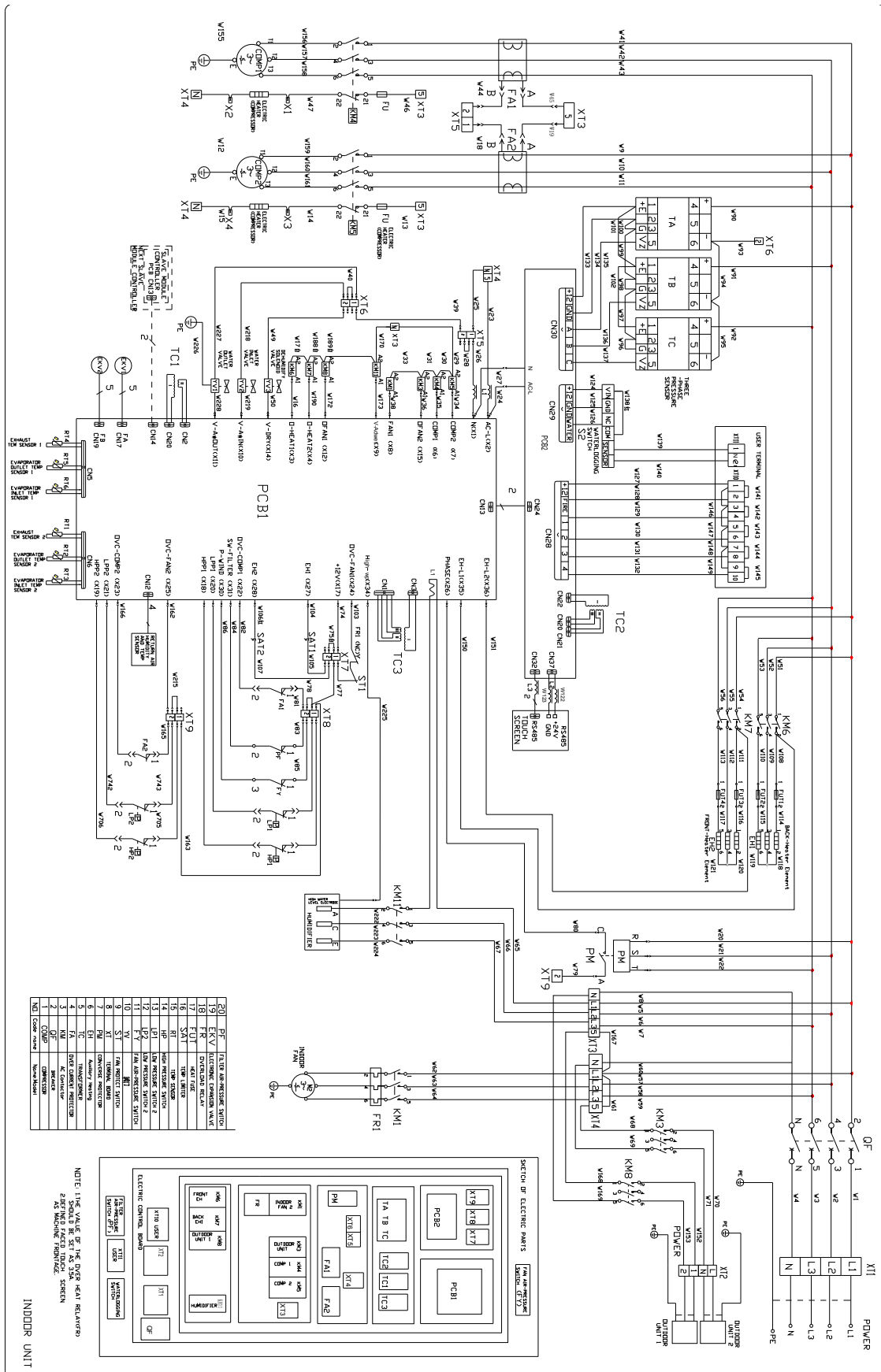

4.2.5 Indoor Unit JKFD25SX2/Na-M(I)

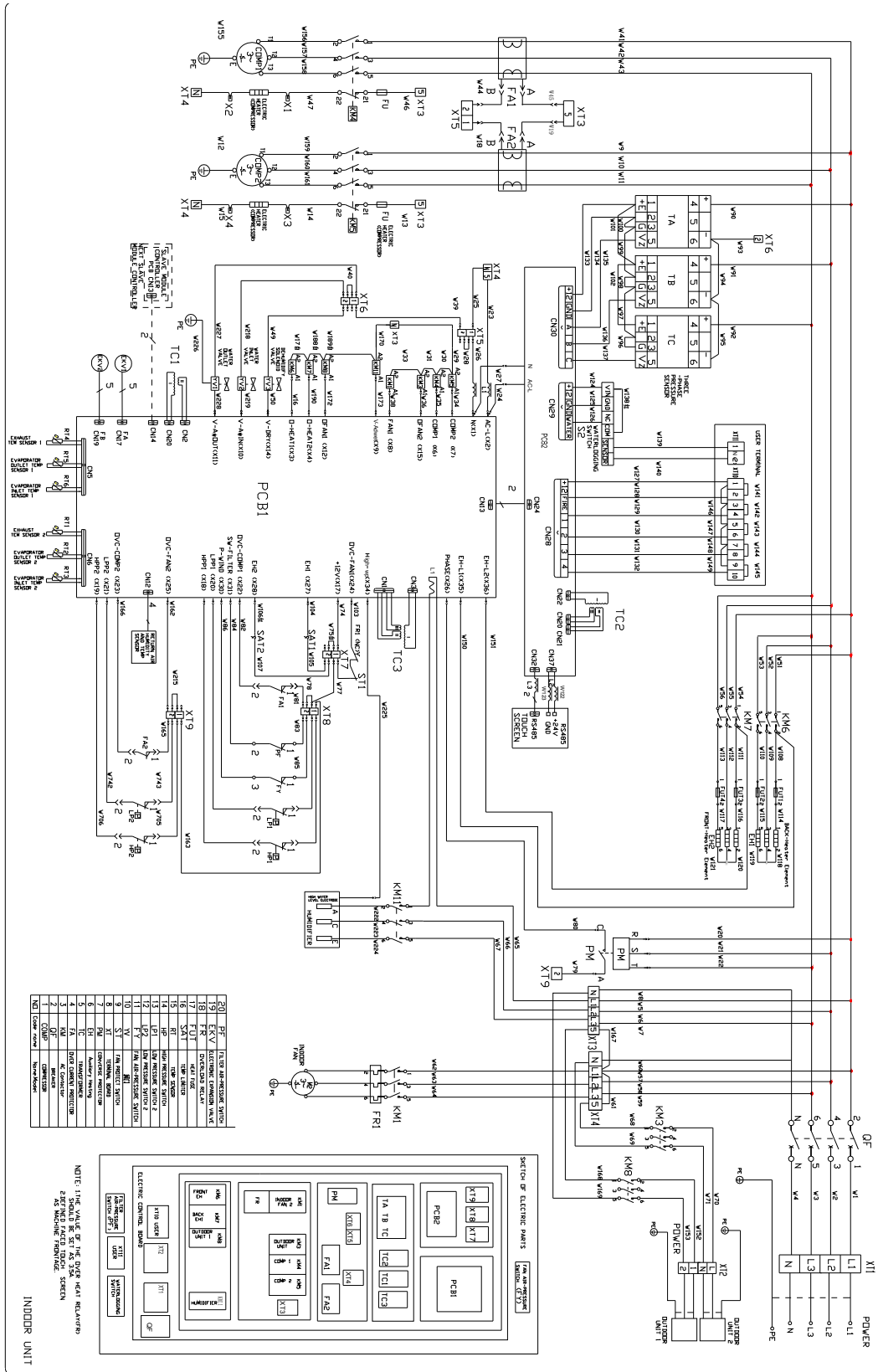

4.2.7 Indoor Unit JKFD5P/Na-E(O)、JKFD7P/Na-E(O)

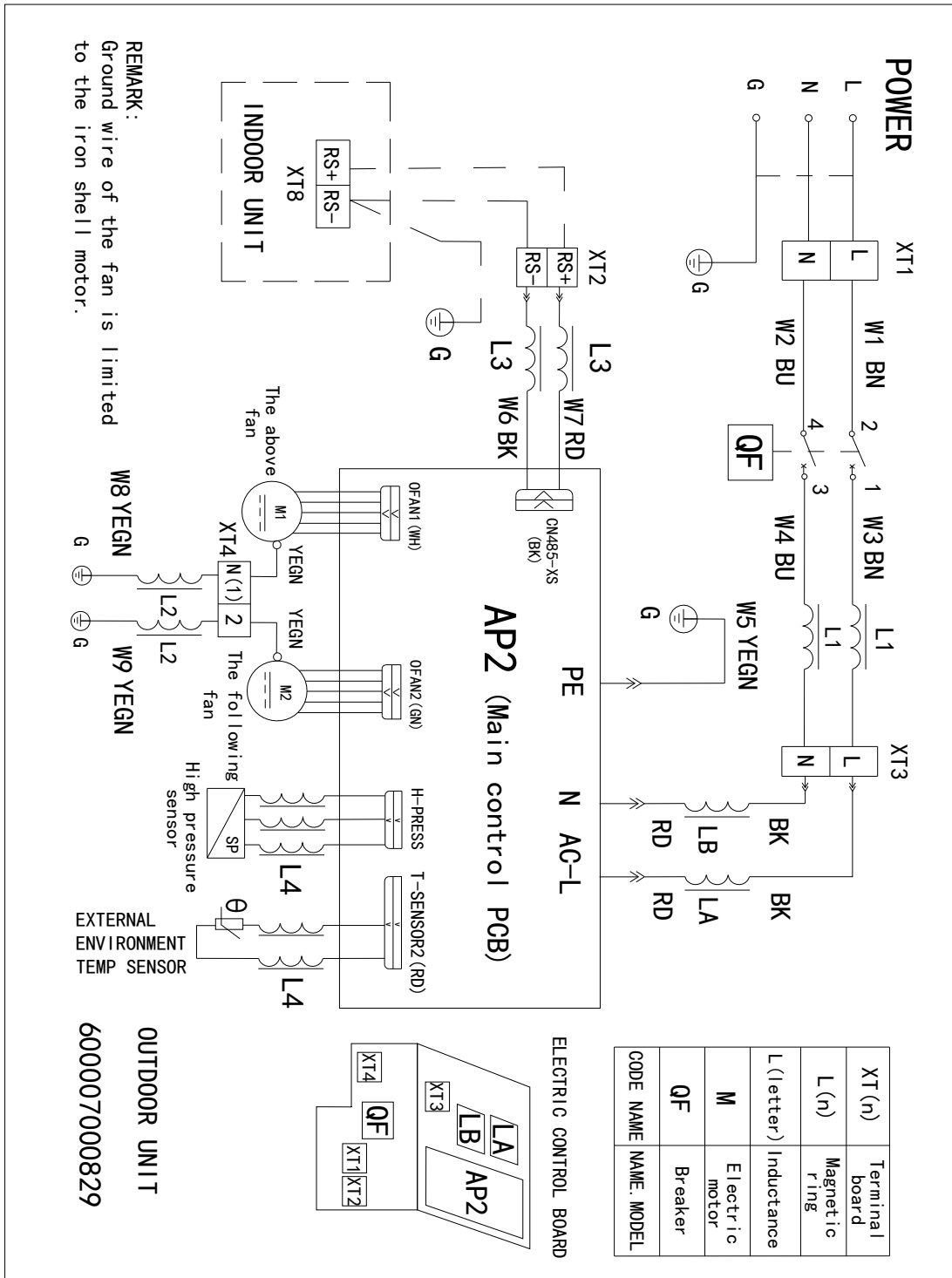

REMARK:
Ground wire of the fan is limited to the iron shell motor.



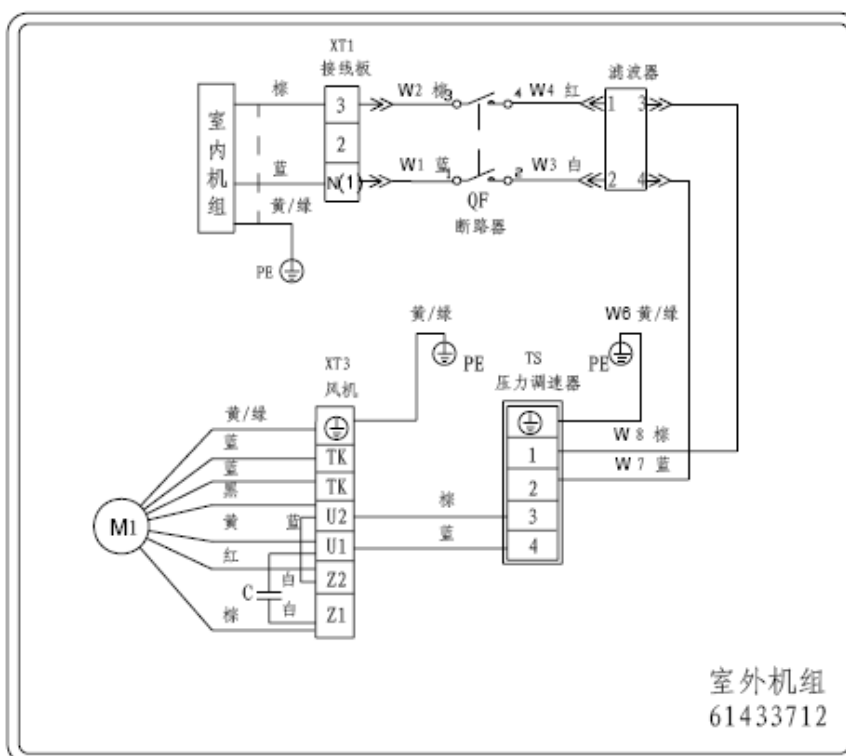

4.2.8 Outdoor Unit JKFD13/NaA-M(O)、JKFD19/NaA-M(O)

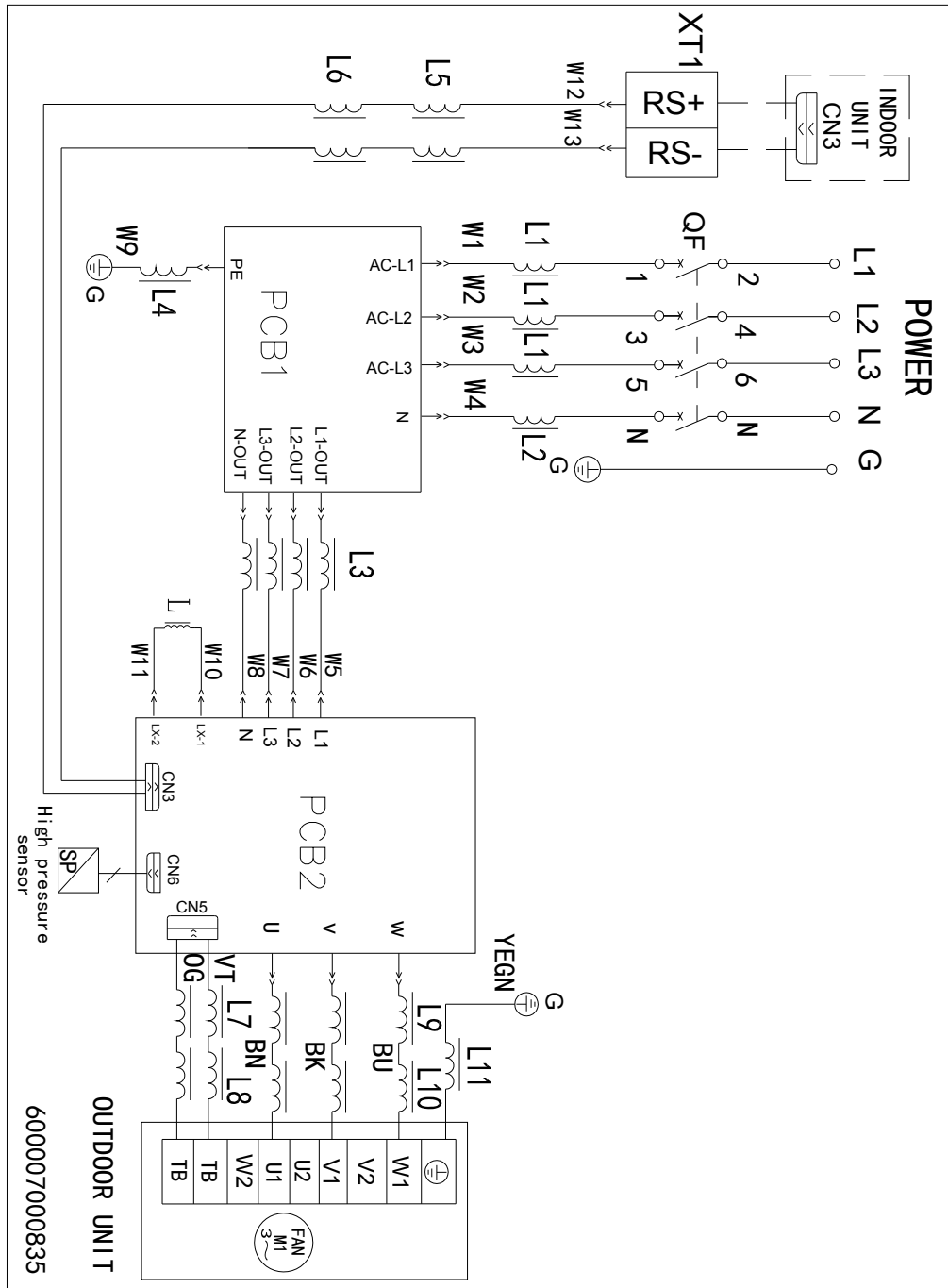





4.2.9 Outdoor Unit JKFD15P/Na-M(O)、JKFD20P/Na-M(O)



4.3 Introduction for Main Electric Parts





Name	Picture	Function
AC contactor		<p>AC contactor controls the power supply for compressor, indoor fan, outdoor fan, Electric heater pipe, electrode humidifier. When the working power terminal of contactor is energized, the contactor, main contact and auxiliary contact which are normally open will be conductive. The auxiliary contact which is normally closed will be off. Working voltage of coil is 220V~.</p>
Air switch		<p>When there is overload or short circuit, air switch will be activated to cut off the power to protect the unit.</p>
Overcurrent protector		<p>Overcurrent protector will detect the current to the wire of a load. When the current is bigger than the activation value of overcurrent protector, its normally closed contact will be off. This contact usually connects to the port of alarm of controller so at that time, the controller will give alarm.</p>
Fusible cutout		<p>If fusible cutout connects to circuit, controller will not give alarm but electric heater will not work. In that case, the fusible cutout may be damaged. Check if it is still conductive by universal meter. If it is conductive, it is good while if not, it is damaged.</p>

<p>Thermostat</p>		<p>When thermostat connects to circuit, if controller gives alarm, electric heat doesn't work and fusible cutout doesn't have malfunction, the thermostat may have malfunction. Check if it is still conductive by universal meter. If it is conductive, it is good while if not, it is damaged.</p>
<p>Thermal relay</p>		<p>Thermal relay will detect the current to the wire of a load. When the current is bigger than the activation value of thermal relay, its normally open contact will close and its normally closed contact will be off. The normal closed contact usually connects to the port of alarm of controller so at that time, the controller will give alarm. Installation of thermal relay includes independent type and integrated type. The independently installed thermal relay is separate from AC contactor and installed below the AC contactor.</p>
<p>Phase reversal protector</p>		<p>After three-phase power supply is connected, measure output contact of phase reversal protector is closed. If it is closed, the phase sequence is correct while if not, the sequence is wrong, which shall be solved by switching any two wire of the three-phase power.</p>
<p>Flooding switch</p>		<p>It is used to detect if there is water on floor.</p>

5. Disassembly and Assembly of the Unit

5.1 Introduction to Key Parts

Picture	Name	Function
	Compressor	Core of cooling system; provides energy for cyclic flow of refrigerant
	Electronic Expansion Valve	Throttle device inside the cooling system. Throttle liquid refrigerant with high pressure and reduce its pressure; Guarantee pressure difference between condenser and evaporator; Make refrigerant entering evaporator evaporate and absorb heat under designed low pressure and adjust its quantity to adapt the change of evaporator load so that the system can stably operate.
	Solenoid valve	Turn on or off the pipeline of refrigerant system to control flow of refrigerant. There are feed Solenoid valve, dry Solenoid valve and by-pass Solenoid valve.

	<p>Humidifier</p>	<p>Humidify the air</p>
	<p>Centrifugal fan</p>	<p>Make air circularly flow and forcibly exchange heat with evaporator. The motor of outer rotor type centrifugal fan is built-in which doesn't need to be maintained during operation.</p>
	<p>Auxiliary electric heater</p>	<p>For heating air.</p>
	<p>Condenser fan</p>	<p>Outdoor fan for heat exchange will force air to exchange heat with outdoor heat exchanger</p>
	<p>Speed regulator of condenser fan</p>	<p>By sensing the change of condensing pressure, it controls the speed of condenser fan. It can effectively control condensing pressure during low temperature refrigeration.</p>

5.2 Assembly and Disassembly of Parts

5.2.1 Compressor

(1) Removal of Compressor

- ◆ Cut off power supply of the unit;
- ◆ Reclaim the refrigerant;
- ◆ Remove suction and discharge pipes of compressor;
- ◆ Remove power line of compressor;
- ◆ Remove retaining bolt of compressor;
- ◆ Remove compressor.

(2) Assemble compressor

- ◆ Place the compressor;
- ◆ Screw the retaining bolt of compressor;
- ◆ Assemble suction and discharge pipes of compressor;
- ◆ Assemble power cord of compressor;
- ◆ Vacuumize the system and maintain the pressure to make sure leak tightness of the system;
- ◆ Recharge refrigerant.



5.2.2 Centrifugal fan

(1) Remove fan

- ◆ Cut off power supply for the unit;
- ◆ Remove retaining bolt;
- ◆ Remove connecting line between fan and mainboard;
- ◆ Remove rubber washer;
- ◆ Remove compressor.

(2) Assemble fan

- ◆ Assemble rubber washer;
- ◆ Assemble fan;
- ◆ Assemble retaining bolt;
- ◆ Assemble connecting line between the fan and the mainboard.



and

5.2.3 Humidifier

Humidifier Consists of three main parts: humidifying tank, discharge, valve and feed valve

(1) Replace humidifying tank:

Disassembly steps:

- ◆ Catch joint of electrode and push it downward for 2mm along the steam cylinder.
- ◆ Loosen clamp of humidifying tank and open its cover;
- ◆ Remove the electrode;
- ◆ Remove O type joint ring of electrode

Assembly steps:

Assemble the humidifier based on the reverse steps of the disassembly.

Note:

- ◆ Before assembly of humidifying tank, check the O type joint ring. If it is damaged, replace it;
- ◆ Place the O type joint ring on electrode and insert the electrode into the cover of humidifying tank. Make sure the joint is locked;
- ◆ Place the humidifying cover on proper position and fix it with clamp;
- ◆ Place the humidifying tank on retaining device on both sides or the rear. Push the tank downward along the discharge valve until it can't be pushed anymore.

(2) Replace discharge valve

Before removal of discharge valve, remove dehumidifying tank firstly. The steps are as follows:

- ◆ Remove cable;
- ◆ Loosen hose clamp and remove water-in hose;
- ◆ Remove 2 retaining screws and discharge valve;
- ◆ Disassembly of discharge valve: firstly remove nut A and then coil B. Catch retaining ring C and remove valve D vertically. Then separate the ring from valve.

The steps of assembly of discharge valve are reverse steps of disassembly.

(3) Replace feed valve:

Before removal of feed valve, remove humidifying tank firstly. The steps are as follows:

- ◆ Remove cable;
- ◆ Loosen hose clamp and separate water-in hose;
- ◆ Remove water-in nut.
- ◆ Remove 2 retaining screws and discharge valve.

Assembly of feed valve are reverse steps above.



6. Exploded View and Parts List

(1) Indoor Unit JKFD5QSR/Na-E(I)、JKFD5CR/Na-E(I)

◆ Exploded view of JKFD5QSR/Na-E(I) (applicable to JKFD5CR/Na-E(I))

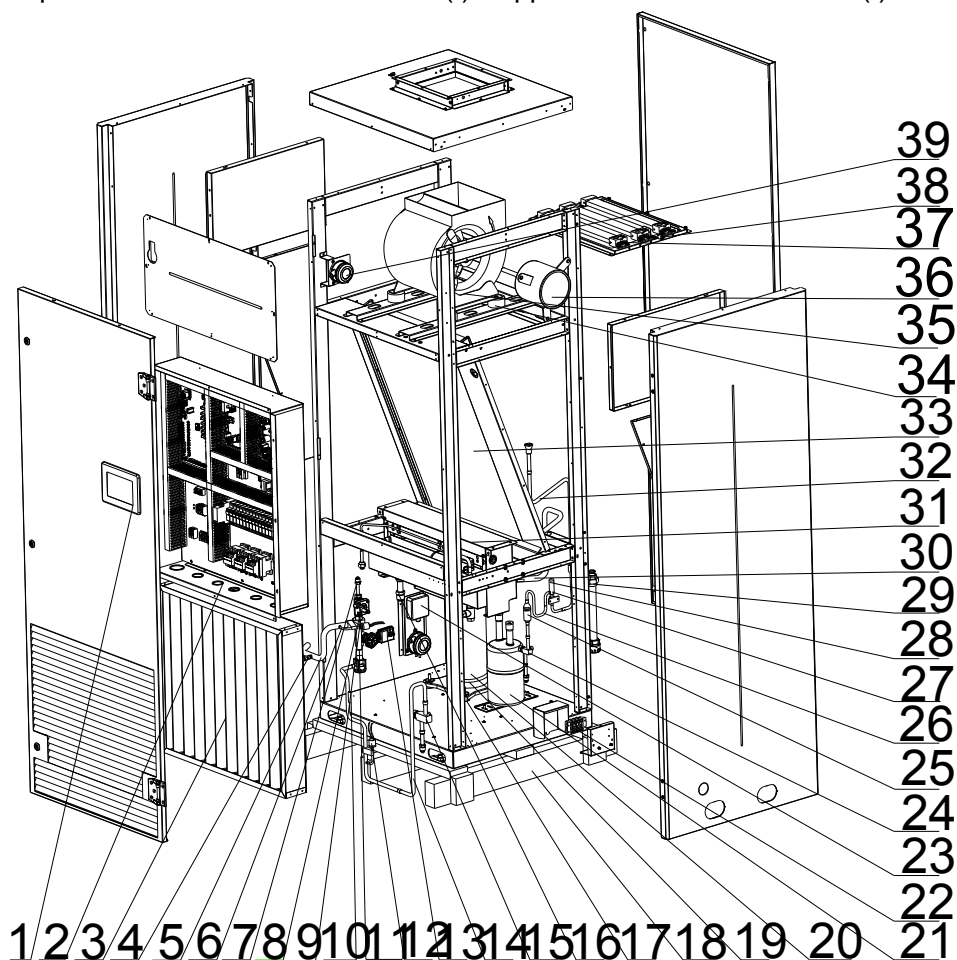

◆ Parts' list for JKFD5QSR/Na-E(I)

No.	Part Name	Material Code	Q'ty
1	Display Board	300001000009	1
2	Electric Cabinet Assy	100003000028	1
3	Primary filter	710024000004	1
4	Nozzle for Adding Freon	06120016	1
5	Inhalation Tube Sub-assy	030010000171	1
6	Pressure Protect Switch	4602001575	1
7	Discharge pipe Sub-Assy	030022000029	1
8	Electromagnetic water valve	43042800025	1
9	Magnet Coil (electromagnetic valve)	43042800026	1
10	Temperature Sensor	39008000096G	1
11	Water inlet pipe sub-assy 1	030059000033	1
12	Pressure Protect Switch	4602001561	1

13	Detecting Plate	30270005	1
14	Discharge Tube Sub-assy	030013000146	1
15	Square Valve	07138800	1
16	Drainage Pipe Sub-assy 1	030065000007	1
17	Compressor Gasket	76812203	1
18	Package Base	50233733	1
19	Electrical Heater(Compressor)	7651521237	1
20	Compressor and Fittings	00203720	1
21	Gas-liquid Separator	07424146	1
22	Terminal Board	42010052	1
23	Water Immersion Switch	45020501	1
24	Square Valve	07130366	1
25	Strainer	07213051	1
26	Electric Expansion Valve Sub-Assy	030026000057	1
27	Electronic Expansion Valve	43042800069	1
28	Electric Expand Valve Fitting	4304413228	1
29	Drainage Pipe Sub-assy	04263700083	1
30	Connection pipe sub-assy	030062000132	1
31	Humidifier Assy	000156000002	1
32	Connection pipe sub-assy	030062000133	1
33	Evaporator Assy	011001000068	1
34	Rubber cushion	76018401	1
35	Motor for Centrifugal Fan	15403719	1
36	Fan Motor	1570371101	1
37	Electric Heater	32105200001	1
38	Temperature Limiter	46010514	1
39	Pressure Difference Switch	46028251	1

(Refer to actual products for unit structure and materials.)

◆ Parts list of model JKFD5CR/Na-E(I)

Compared with model JKFD5QSR/Na-E(I), it just adds false ogive. So please refer to parts list of model JKFD5QSR/Na-E(I).

(2) Indoor Unit JKFD7CR/Na-M(I)、JKFD7QSR/Na-M(I)

◆ Exploded view of JKFD7QSR/Na-M(I) (applicable to JKFD7CR/Na-M(I))

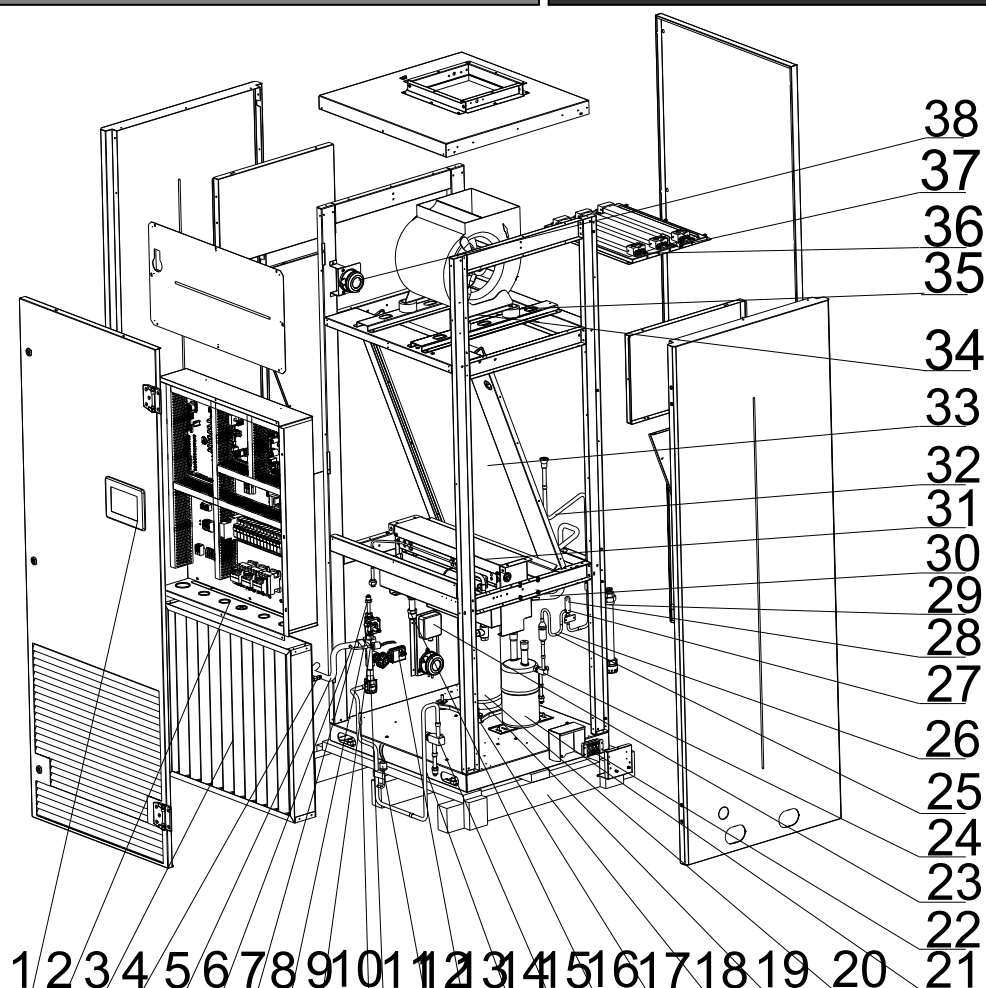

◆ Parts list of modle JKFD7QSR/Na-M(l)

No.	Part Name	Material Code	Q'ty
1	Display Board	300001000009	1
2	Electric Cabinet Assy	100003000027	1
3	Primary filter	710024000004	1
4	Nozzle for Adding Freon	06120016	1
5	Inhalation Tube Sub-assy	030010000171	1
6	Pressure Protect Switch	4602001575	1
7	Discharge pipe Sub-Assy	030022000029	1
8	Electromagnetic water valve	43042800025	1
9	Magnet Coil (electromagnetic valve)	43042800026	1
10	Temperature Sensor	39008000096G	1
11	Water inlet pipe sub-assy 1	030059000033	1
12	Pressure Protect Switch	4602001561	1
13	Detecting Plate	30270005	1
14	Discharge Tube Sub-assy	030013000146	1
15	Square Valve	07138800	1
16	Drainage Pipe Sub-assy 1	030065000007	1

17	Compressor Gasket	76812203	1
18	Package Base	50233733	1
19	Electrical Heater(Compressor)	7651521237	1
20	Compressor and Fittings	00203711	1
21	Gas-liquid Separator	07424146	1
22	Terminal Board	42010052	1
23	Water Immersion Switch	45020501	1
24	Square Valve	07130366	1
25	Strainer	07213051	1
26	Electric Expansion Valve Sub-Assy	030026000057	1
27	Electronic Expansion Valve	43042800069	1
28	Electric Expand Valve Fitting	4304413228	1
29	Drainage Pipe Sub-assy	04263700083	1
30	Connection pipe sub-assy	030062000132	1
31	Humidifier Assy	000156000002	1
32	Connection pipe sub-assy	030062000133	1
33	Evaporator Assy	011001000068	1
34	Centrifugal Fan sub-assy	15403718	1
35	Rubber cushion	76018401	1
36	Electric Heater	32105200001	1
37	Temperature Limiter	46010514	1
38	Pressure Difference Switch	46028251	1

◆ Parts' list of JKFD7CR/Na-M(I)

Compared with model JKFD7QSR/Na-M(I), it just doesn't have false ogive. So please refer to parts list of model JKFD7QSR/Na-M(I).

(3) Indoor Unit JKFD15CR/Na-M(I)、JKFD15QSR/Na-M(I)、JKFD20CR/Na-M(I)、JKFD20QSR/Na-M(I)

◆ Exploded view of JKFD15QSR/Na-M(I) (applicable to JKFD15CR/Na-M(I)、JKFD20CR/Na-M(I)、JKFD20QSR/Na-M(I))

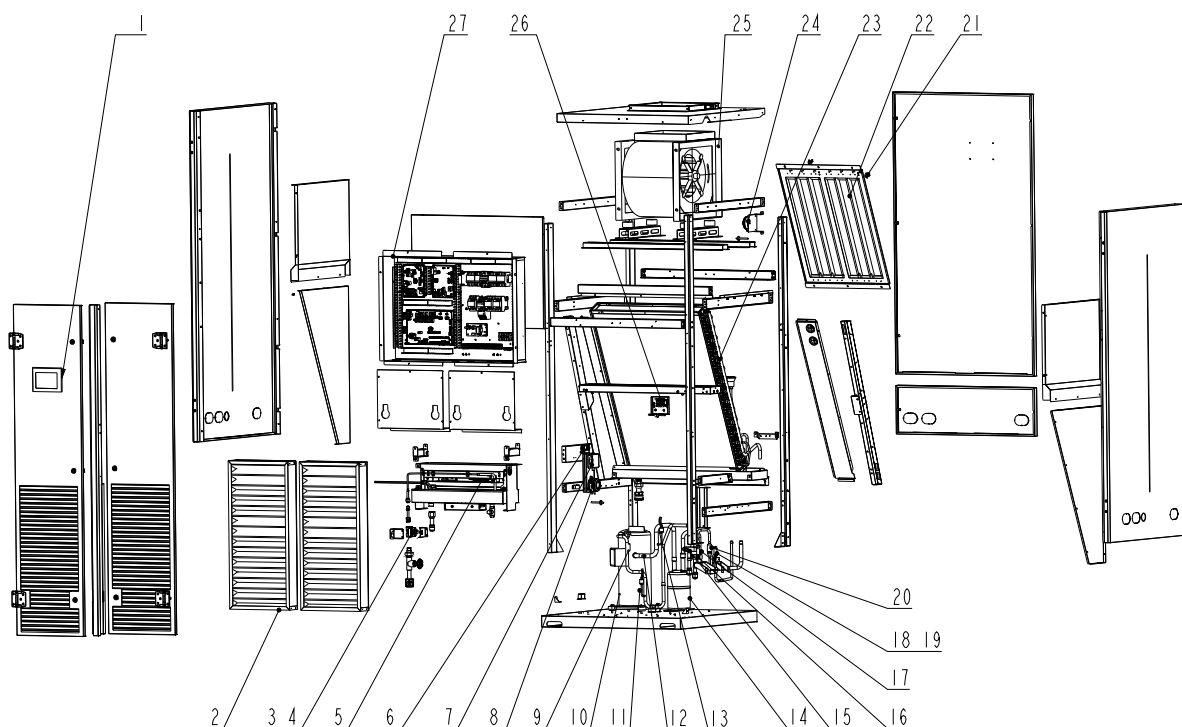

◆ Parts' list of JKFD15QSR/Na-M(I)

No.	Part Name	Material Code	Q'ty
1	Display Board	300001000009	1
2	Thick Filter	710024000005	1
3	Electromagnetic water valve	'43042800025	1
4	Magnet Coil (electromagnetic valve)	'43042800026	1
5	Humidifier Assy	000156000002	1
6	Detecting plate	'30270005	1
7	Water Immersion Switch	'45020501	1
8	pressure difference switch	'46028251	1
9	Temp Sensor Sleeve	'05210001	1
10	Compressor and Fittings	00203700039	1
11	Pressure Protect Switch	'4602001559	1
12	Nozzle for Adding Freon	'06120016	1
13	Pressure Protect Switch	46020015104	1
14	Gas-liquid Separator	'07424146	1
15	Square Valve	'07130128	1
16	Square Valve	07138800	1
17	Temp Sensor Sleeve	'05212423	1
18	Electronic Expansion Valve	'43044100173	1
19	Electric Expand Valve Fitting	'4304413228	1
20	Strainer	'07213051	1
21	Temperature Limiter	'46010520	1

22	Electric Heater	32105200001	1
23	Evaporator Assy	011001000069	1
24	Pressure difference switch sub-assy 2	'46028000001	1
25	Centrifugal Fan sub-assy	150184042	1
26	Terminal Board	'42010052	1
27	Electric Box Assy	'100002000146	1

◆ Parts' list of JKFD15CR/Na-M(I)

Compared with model JKFD15QSR/Na-M(I), it just add false ogive. So please refer to parts list of model JKFD15QSR/Na-M(I).

◆ Parts' list of JKFD20QSR/Na-M(I)

No.	Part Name	Material Code	Q'ty
1	Display Board	300001000009	1
2	Thick Filter	710024000005	1
3	Electromagnetic water valve	'43042800025	1
4	Magnet Coil (electromagnetic valve)	'43042800026	1
5	Humidifier Assy	000156000002	1
6	Detecting plate	'30270005	1
7	Water Immersion Switch	'45020501	1
8	pressure difference switch	'46028251	1
9	Temp Sensor Sleeving	'05210001	1
10	Compressor and Fittings	0020223101	1
11	Pressure Protect Switch	'4602001559	1
12	Nozzle for Adding Freon	'06120016	1
13	Pressure Protect Switch	46020015104	1
14	Gas-liquid Separator	'07424146	1
15	Square Valve	'07334103	1
16	Square Valve	'07130128	1
17	Temp Sensor Sleeving	'05212423	1
18	Electronic Expansion Valve	'43044100173	1
19	Electric Expand Valve Fitting	'4304413228	1
20	Strainer	'07213051	1
21	Temperature Limiter	'46010520	1
22	Electric Heater	3210521510	1
23	Evaporator Assy	011001000069	1
24	Pressure difference switch sub-assy 2	'46028000001	1
25	Centrifugal Fan sub-assy	'150184066	1
26	Terminal Board	'42010052	1
27	Electric Box Assy	100002000139	1

◆ Parts' list of JKFD20CR/Na-M(I)

Compared with model JKFD20QSR/Na-M(I), it just add false ogive. So please refer to parts list of model JKFD20QSR/Na-M(I).

(4) Indoor Unit JKFD25C2/Na-M(I)、JKFD25QS2/Na-M(I)

◆ Exploded view of JKFD25QS2/Na-M(I) (applicable to JKFD25C2/Na-M(I))

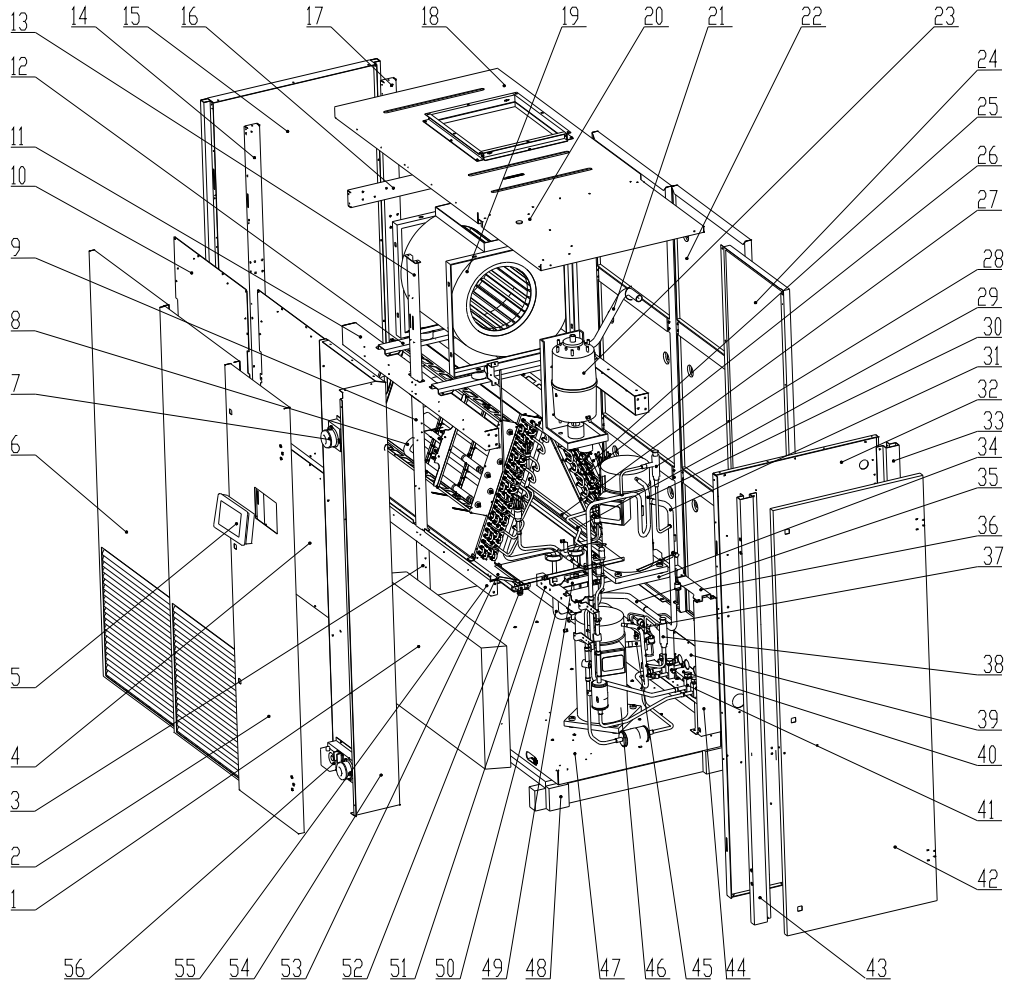

◆ Parts' list of JKFD25QS2/Na-M(I)

No.	Part Name	Material Code	Q'ty
1	Primary strainer assy	07413713	2
2	Electric control door	01393753P	1
3	Column (middle)	01853756P	2
4	Wind shield2	01353743P	2
5	Touch screen ZE130	35018017	1
6	Panel (front)	01543801	2
7	Pressure difference switch2	01325237	1
8	Electric heater BKR 6000W/380V	32103705	1
9	Column (middle)	01853761P	2

10	Wind shield	01353742P	2
11	Cross beam(up)	01873809P	2
12	Mounting rack of fan	01323769P	2
13	Column (upper)	01853762P	2
14	Column sub-assy (front left)	01853751	1
15	Left panel	01643727	1
16	Longitudinal beam (left)	01873806	2
17	Column sub-assy (rear left)	01853752	1
18	Top panel	01263739	1
19	Centrifugal fan SYB-355	150184067	1
20	Top panel2	01263740	1
21	Nozzle sub-assy	05033775	1
22	Panel	01543800	2
23	Electrode humidifier KUE0202000	07493701	1
24	Rear electric control plate	02223767	1
25	Electric heater BKR 6000W/380V	32103704	1
26	Evaporator	01023726	1
27	Fixing part 2 of evaporator	01093751P	1
28	Hot gas bypass valve sub-assy2	-	1
29	Connection pipe 1 (electronic expansion valve)	05023806	1
30	Discharge pipe2	04633794	1
31	Air-return pipe2	04673808	1
32	Isolation sheet	01243743P	1
33	Column sub-assy (right rear)	01853759P	1
34	Installation beam of compressor	01873787P	2
35	Air-return pipe	04653784	1
36	Fixing beam 3	01873850P	1
37	Discharge pipe1	04633795	1
38	Hot gas bypass valve sub-assy1	-	1
39	Sealing plate 1	01343758P	1
40	Sealing plate 2	01343757P	1
41	Valve	07303702	1
42	Right door plate	02223764P	1
43	Column sub-assy (front right)	01853753P	1
44	Column (compressor)	01853758P	1
45	Air-return pipe1	04673809	1
46	Compressor and fittings ZP61KCE-TFD-522	00205272	2
47	Base	01283780	1
48	Packing base	50233730	1

49	Cross beam2	01873808P	1
50	Air-return pipe 3	04653783	1
51	Fixing bea 1	01873784	1
52	Water tray	01283781	2
53	Fixing part 1 of evaporator	01093749P	1
54	Electric cabinet	01393758P	1
55	Cross beam	01873807P	2
56	Pressure difference switch1	01325236	1

◆ Parts' list of JKFD25C2/Na-M(I)

Compared with model JKFD25QS2/Na-M(I), it just add false ogive (01523714) . So please refer to parts list of model JKFD25QS2/Na-M(I).

(5) Indoor Unit JKFD25SX2/Na-M(I)

◆ Exploded view of JKFD25SX2/Na-M(I)

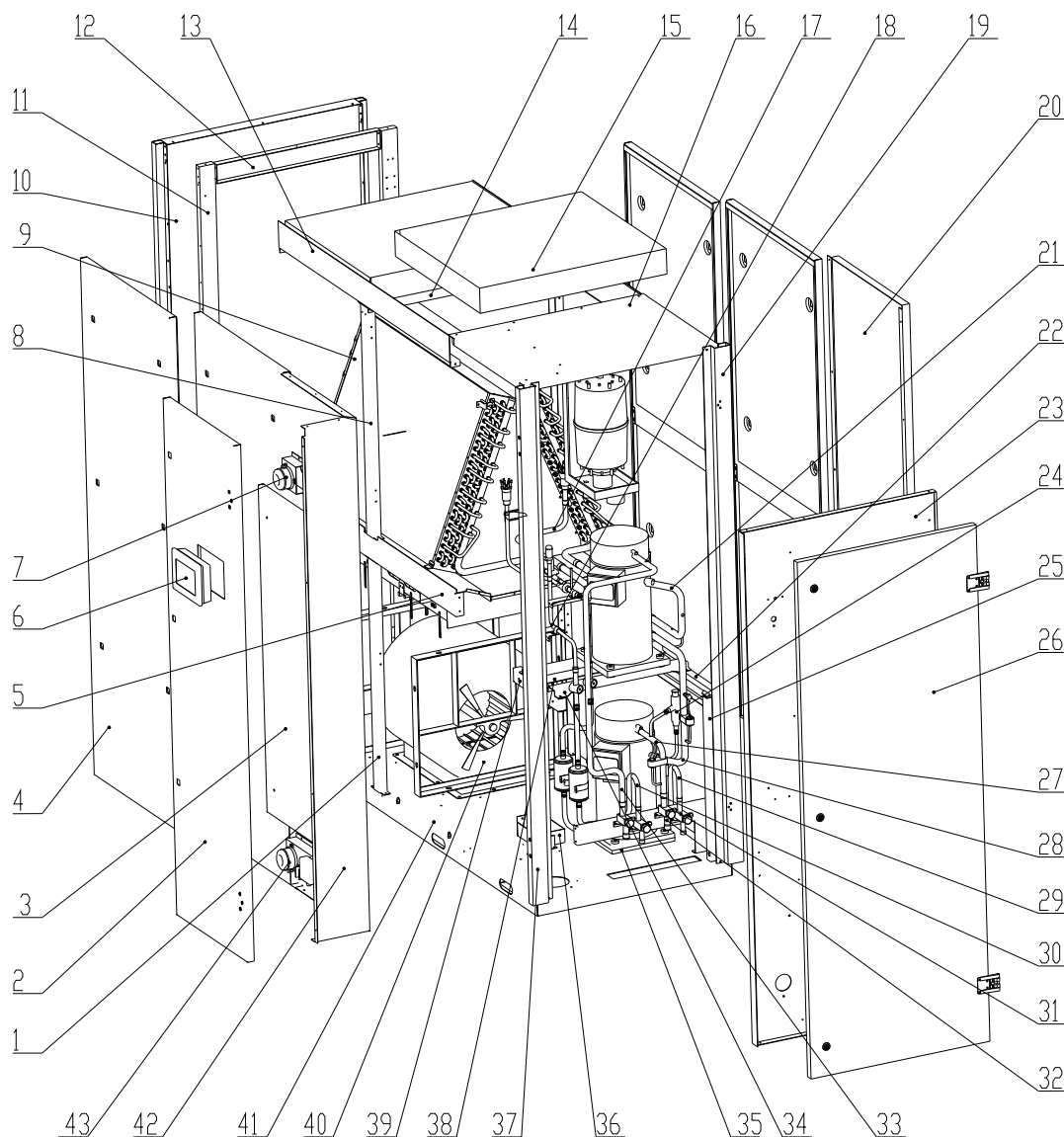

◆ Parts' list of JKFD25SX2/Na-M(I)

No.	Part Name	Material Code	Q'ty
1	Column (lower)	01853777P	4
2	Electric control door	01393753P	1
3	Mounting plate of electric part	01323785	1
4	Panel	01543800	4
5	Cross beam(middle)	01883704P	2
6	Touch screen ZE130	35018017	1
7	Pressure difference switch2	01325237	1
8	Upper column	01853744P	4
9	Evaporator	01023728	1
10	Left panel	01543858	1
11	Column	01853738	2
12	Upper longitudinal beam	01873782	1
13	Cross beam(strainer)	01883703P	2
14	Longitudinal beam(strainer)	01873789P	2
15	Primary strainer assy	07413715	2
16	Top panel	01263733	1
17	Connection pipe 2	05033765	1
18	Electronic expansion valve 2	07333734	1
19	Column sub-assy (right rear)	01853740P	1
20	Rear electric control plate	02223766	1
21	Air-return pipe2	04673739	1
22	Fixing beam 3	01873786P	1
23	Isolation sheet	01243734P	1
24	Hot gas bypass valve sub-assy	07333730	2
25	Column (fixing beam)	01853739P	1
26	Right door plate	02223764P	1
27	Discharge pipe1	04633744	1
28	Air-return pipe1	04673738	1
29	Strainer 1	07413717	1
30	Strainer 2	07413718	1
31	Cut-off valve 1	07333749	2
32	Cut-off valve 2	07333750	2
33	Discharge pipe2	04633745	1
34	Installation beam of compressor	01873787P	2
35	Compressor and fittings ZP61KCE-TFD-522	00205272	2
36	Water tray(base)	01283763P	1
37	Column sub-assy (right front)	01853742P	1
38	Fixing bea 2	01873785P	1
39	Fixing bea 1	01873784P	1

40	Centrifugal fan SYB-355II(1.8-6)	15403716	1
41	Base	01283799	1
42	Electric cabinet	01393751P	1
43	Pressure difference switch1	01325236	1

(6) Indoor Unit JKFD40C2/Na-M(I)、JKFD40QS2/Na-M(I)

◆ Exploded view of JKFD40QS2/Na-M(I) (applicable to JKFD40C2/Na-M(I))

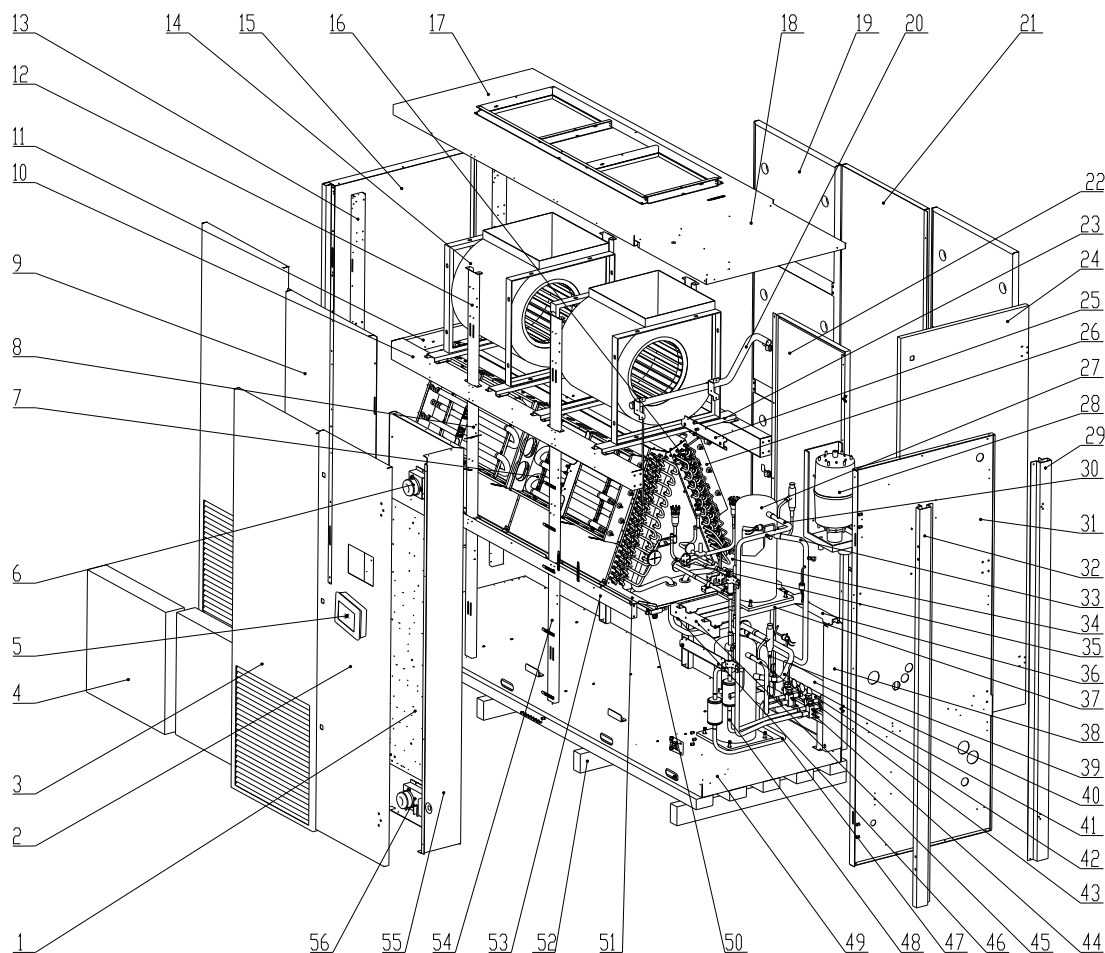

◆ Parts' list of JKFD40QS2/Na-M(I)

No.	Part Name	Material Code	Q'ty
1	Mounting plate of electric part	01323776	1
2	Electric control door	01393753P	1
3	Panel (front right)	01543804	2
4	Primary strainer assy	07413716	3
5	Touch screen ZE130	35018017	1
6	Pressure difference switch2	01325237	1
7	Electric heater BKR 4500W/380V	32103706	2

8	Column (middle)	01853767P	4
9	Panel (front middle)	01543803	1
10	Cross beam(up)	01873810P	2
11	Longitudinal beam (left)	01873812	3
12	Column (upper)	01853765P	4
13	Column (left)	01853768P	2
14	Centrifugal fan	150184066	2
15	Left panel	01643727	1
16	Evaporator	01023727	1
17	Top panel	01263744	1
18	Top panel2	01263740	1
19	Rear panel	01643726	2
20	Nozzle sub-assy	05033839	1
21	Middle panel	01643701	1
22	Rear electric control plate	02223767	1
23	Mounting rack of fan	01323775P	4
24	Right door plate	02223764P	1
25	Support sub-assy	01893775	2
26	Electric heater BKR 4500W/380V	32103713	1
27	Compressor and fittings ZP83KCE-TFD-522	00202231	2
28	Electrode humidifier KUE0202000	07493701	1
29	Column sub-assy (right rear)	01853759P	1
30	Discharge pipe2	04633741	1
31	Isolation sheet	01243744P	1
32	Column sub-assy (front right)	01853753	1
33	Air-return pipe2	04673752	1
34	Soleplate 1 of evaporator	01093734P	1
35	Connection pipe 2	05033713	1
36	Fixing beam 3	01873786P	1
37	Installation beam of compressor	01873787P	2
38	Column (fixing beam)	01853739P	1
39	Hot gas bypass valve sub-assy1	-	2
40	Sealing plate 1	01343771P	1
41	Air-return pipe1	04673751	1
42	Sealing plate 2	01343770P	1
43	Discharge pipe1	04633740	1
44	Valve	07303703	1
45	Fixing bea 1	01873784P	1
46	Fixing bea 2	01873785P	1
47	Liquid inlet pipe sub-assy 1	04323852	1

48	Liquid inlet pipe sub-assy 2	04323853	1
49	Base	01283786	1
50	Water tray	01283789P	2
51	Soleplate 2 of evaporator	01093736P	1
52	Packing base(wood)	50233727	1
53	Cross beam(lower)	01873811P	2
54	Column (lower)	01853766P	4
55	Electric cabinet	01393773P	1
56	Pressure difference switch1	01325236	1

◆ Parts' list of JKFD40C2/Na-M(I)

Compared with model JKFD40QS2/Na-M(I), it just add false ogive (01523716) . So please refer to parts list of model JKFD40QS2/Na-M(I).

(7) Indoor Unit JKFD40SX2/Na-M(I)

◆ Exploded view of JKFD40SX2/Na-M(I)

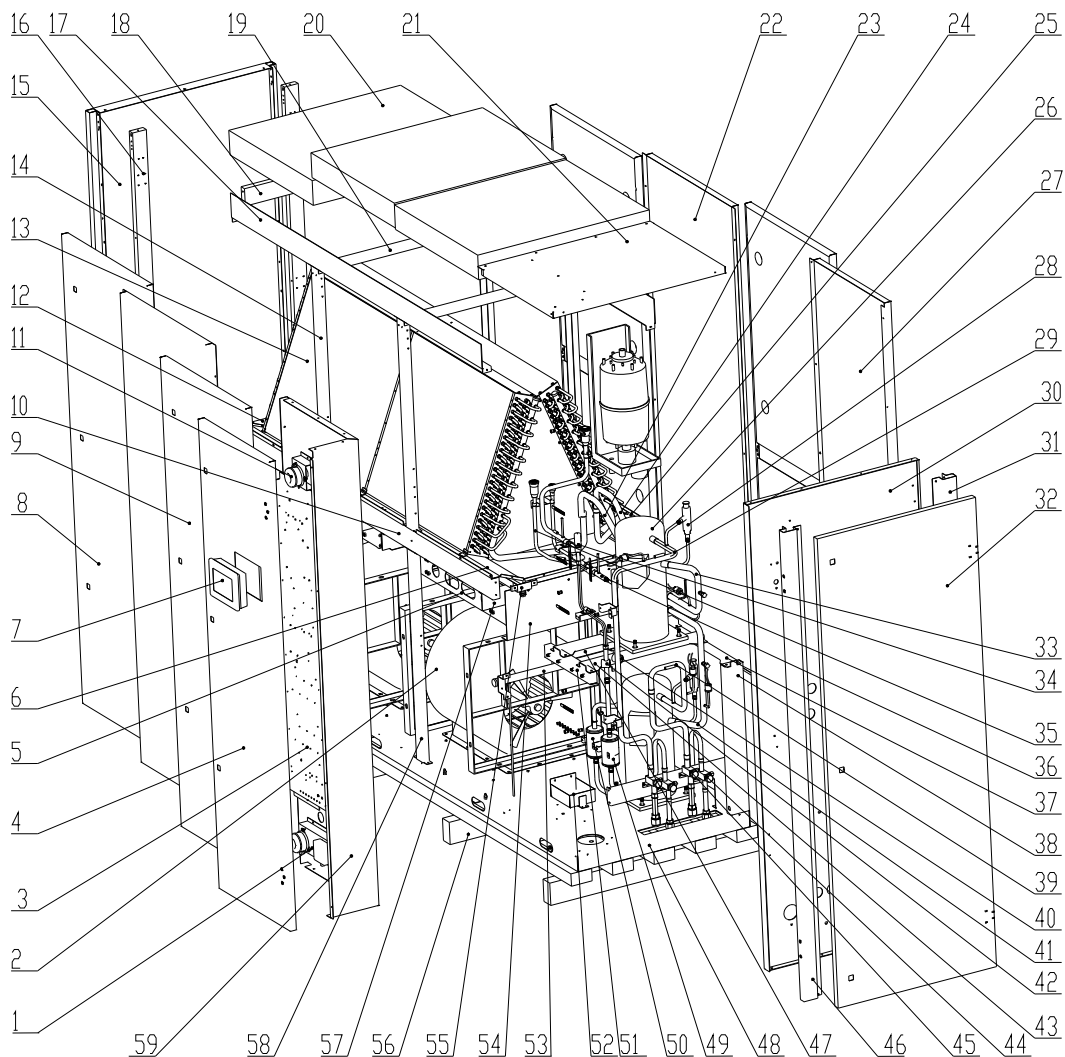

◆ Parts' list of JKFD40SX2/Na-M(I)

No.	Part Name	Material Code	Q'ty
1	Pressure difference switch1	01325236	1
2	Centrifugal fan SYB-355II(1.5-6)	15703707	2
3	Mounting plate of electric part	01323764	1
4	Electric control door	01393753P	1
5	Electric heater BKR 9000W/380V	32103703	2
6	Soleplate 2 of evaporator	01093736P	1
7	Touch screen ZE130	35018017	1
8	Panel	01543799	3
9	Middle and right panel	01543798	1
10	Cross beam	01873783P	2
11	Pressure difference switch2	01325237	1
12	Lower longitudinal beam	01873781	1
13	Evaporator	01023720	1
14	Upper column	01853744P	4
15	Left panel	01543858	1
16	Column	01853738	2
17	Cross beam(strainer)	01873790P	2
18	Upper longitudinal beam	01873782	1
19	Longitudinal beam(strainer)	01873789P	2
20	Primary strainer assy	07413708	3
21	Top panel	01263733	1
22	Middle panel	01643701	2
23	Connection pipe sub-assy1 (air-return pipe)	05023745	1
24	Connection pipe 2(air-return pipe)	05023747	1
25	Soleplate 1 of evaporator	01093734P	1
26	Compressor and fittings ZP83KCE-TFD-522	00202231	2
27	Rear electric control plate	02223766	1
28	Hot gas bypass valve sub-assy	-	2
29	Discharge pipe2	04633731	1
30	Isolation sheet	01243734P	1
31	Column sub-assy (right rear)	01853740P	1
32	Right door plate	02223764P	1
33	Air-return pipe2	04673739	1
34	Electronic expansion valve 2	07333714	1
35	Connection pipe sub-assy 1	05023756	1
36	Electronic expansion valve 1	07333713	1
37	Fixing beam 3	01873786P	1

38	Column (fixing beam)	01853739P	1
39	Discharge pipe1	04633730	1
40	Level glass sub-assy 1	22453701	1
41	Air-return pipe1	04673738	1
42	Level glass sub-assy 2	22453702	1
43	Installation beam of compressor	01873787P	2
44	Cut-off valve 2	07333750	2
45	Cut-off valve 2	07333751	2
46	Column sub-assy (right front)	01853742P	1
47	Fixing bea 2	01873785P	1
48	Base	01283759	1
49	Strainer 2	07413710	1
50	Strainer 1	07413709	1
51	Fixing bea 1	01873784P	1
52	Water tray(base)	01283763P	1
53	Nozzle sub-assy	05023742	1
54	Guard board (electric heater)	01353738P	2
55	Water tray	01283764P	2
56	Packing base(wood)	50233727	1
57	Mounting beam (electric heater)	01323756P	4
58	Column (lower)	01853777P	4
59	Electric cabinet	01393751P	

(8) Outdoor Unit JKFD5P/Na-E(O)、JKFD7P/Na-E(O)

- ◆ Exploded view of JKFD5P/Na-E(O) (applicable to JKFD7P/Na-E(O))

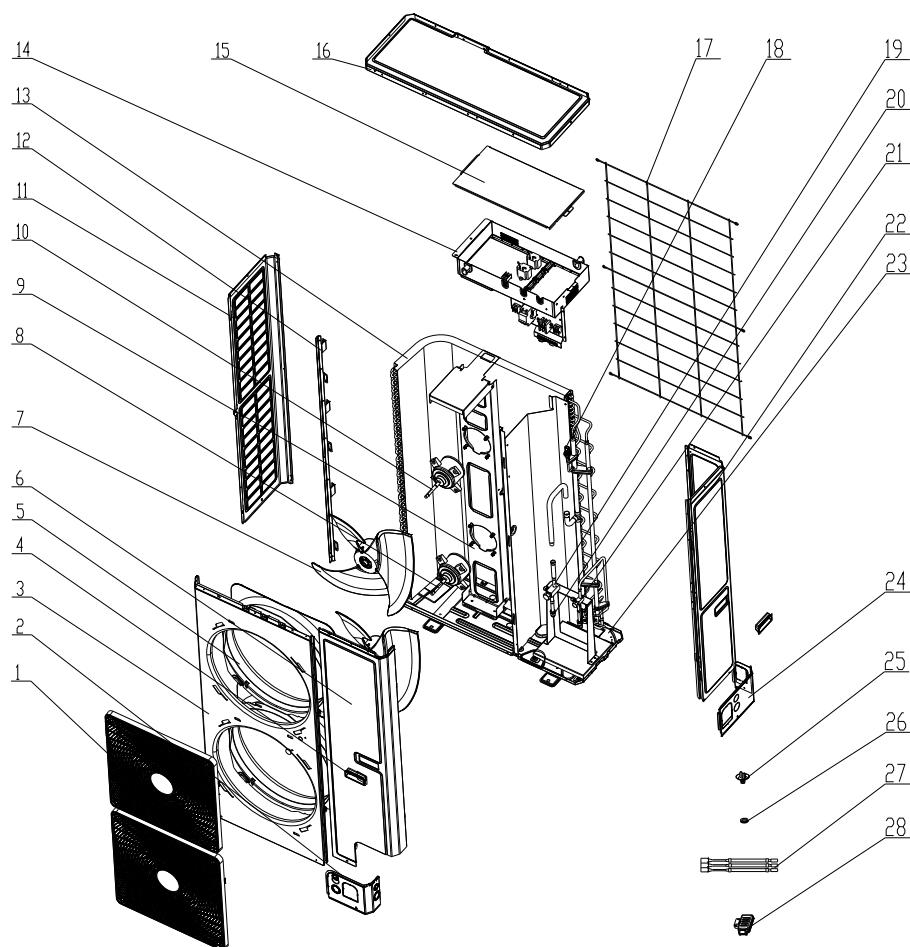

◆ Parts' list of JKFD5P/Na-E(O)

No.	Part Name	Material Code	Q'ty
1	Front Grill	01575200001	1
2	Connection Sheet Assy	01344100091	1
3	Cabinet	01514100002P	1
4	Handle	26904100016	1
5	Diversion Circle	10474100001	1
6	Front Side Plate	01314100012P	1
7	Axial Flow Fan	10338731	1
8	Brushless DC Motor	1570410001301	1
9	Motor Support Sub-Assy	01805200185	1
10	Brushless DC Motor	15704100013	1
11	Left Side Plate	01314100013P	1
12	Supporting Strip(Condenser)	01894100026	1
13	Condenser Assy	011002000122	1
14	Electric Box Sub-Assy	017007000041	1
15	Electric Box Cover	01422200011	1
16	Coping	01264100008P	1
17	Rear Grill	01574100004	1

18	Sensor (High Pressure)	322101032	1
19	Square Valve	07138800	1
20	Sealing Cap of Joint	06640104	1
21	Square Valve	07130366	1
22	Rear Side Plate	01314100014P	1
23	Chassis Sub-assy	01194100051P	1
24	Right Connection Board	01344100003P	1
25	Drainage Connector	06123401	1
26	Drainage hole Cap	06813401	1
27	Temperature Sensor	390001000004	1
28	Sensor Support	26905202	1

(9) Outdoor Unit JKFD13/NaA-M(O)、JKFD19/NaA-M(O)

◆ Exploded view of JKFD19/NaA-M(O) (applicable to JKFD13/NaA-M(O))

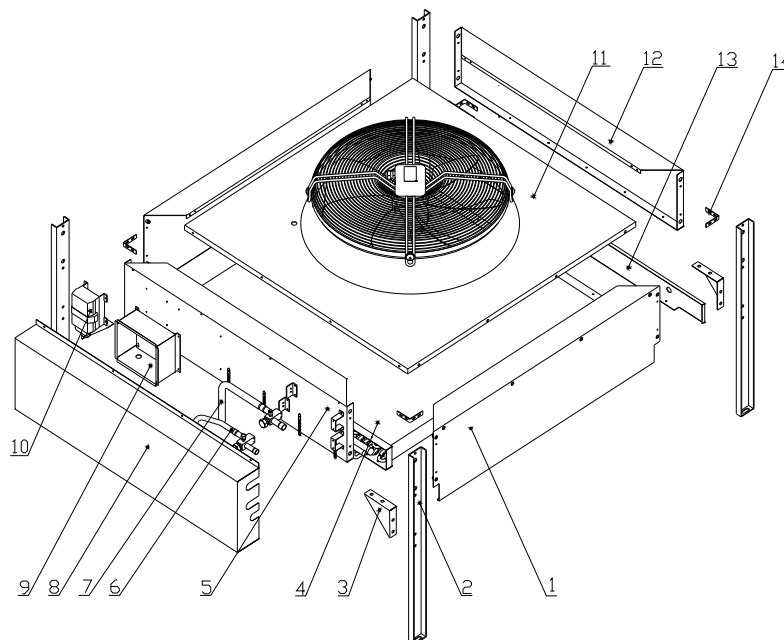

◆ Parts' list of JKFD13/NaA-M(O)

No.	Part Name	Material Code	Q'ty
1	Side plate sub-assy	01313735P	2
2	Support leg	01893728P	4
3	Support stand	01803767P	4
4	Condenser	01123718	1
5	Front side plate sub-assy	01313733P	1
6	Cut-off part	07333806	1
7	Cut-off part	07333807	1
8	Front cover plate	01263731P	1
9	Electric box JKFD13(O)	01393748	1
10	Speed controller of fan	30118025	1

RGE-Z1Q4-7			
11	Fan	15403714	1
12	Rear side plate	01313732P	1
13	Rear cover plate	01263730P	1
14	Connecting part	01343747	4

◆ Parts' list of JKFD19/NaA-M(O)

No.	Part Name	Material Code	Q'ty
1	Side plate sub-assy	01313735P	2
2	Support leg	01893728P	4
3	Support stand	01803767P	4
4	Condenser	01123718	1
5	Front side plate sub-assy	01313733P	1
6	Cut-off part	07333814	1
7	Cut-off part	07333815	1
8	Front cover plate	01263731P	1
9	Electric box JKFD13(O)	01393748	1
10	Speed controller of fan RGE-Z1Q4-7	30118025	1
11	Axial flow fanC-FZ630J	15403715	1
12	Rear side plate	01313732P	1
13	Rear cover plate	01263730P	1
14	Connecting part	01343747	4

(12) Outdoor Unit JKFD15P/Na-M(O)、JKFD20P/Na-M(O)

◆ Exploded view of JKFD15P/Na-M(O) (applicable to JKFD20P/Na-M(O))

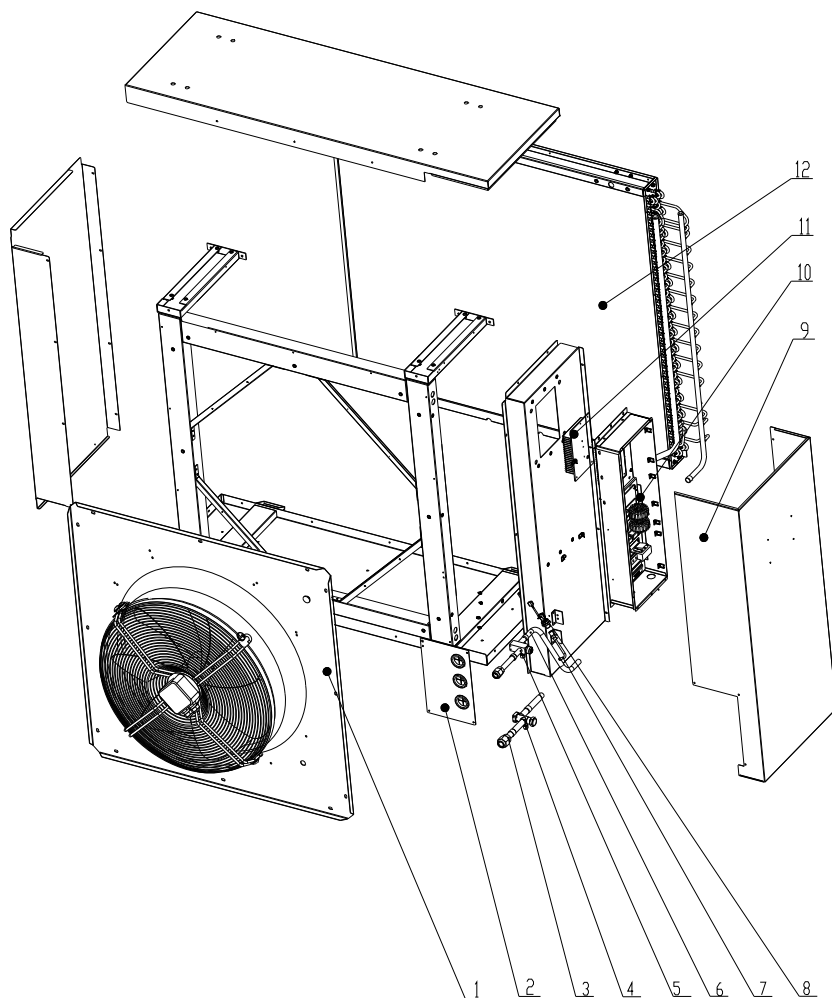

◆ Parts' list of JKFD15P/Na-M(O)、JKFD20P/Na-M(O)

No.	Part Name	Material Code	Q'ty
1	Blower for Axial Fan Sub- Assy	15403700028	1
2	Baffle Plate	012109000020	1
3	Cut-off valve sub-assy 1	030057000044	1
4	Square Valve	07130128	1
5	Square Valve	07138800	1
6	Cut-off valve sub-assy 2	030057000045	1
7	Nozzle for Adding Freon	06120012	1
8	Sensor (High Pressure)	322101033	1
9	Cover Plate	012035000043	1
10	Electric Box Assy	100002000128	1
11	Radiator	49018000102	1
12	Condenser Assy	011002000123	1

JF00301628

GREE ELECTRIC APPLIANCES, INC. OF ZHUHAI

Add: West inji Rd, Qianshan,Zhuhai,Guangdong,China,519070

Tel: (+86-756) 8522218 Fax: (+86-756) 8669426

E-mail: gree@gree.com.cn www.gree.com

For continuous improvement in the products, Gree reserves the right to modify the product specification and appearance in this manual without notice and without incurring any obligations.